

DEPTH 2100

Installation and Operation Manual

English	3
Français	11
Deutsch	18
Nederlands	25
Svenska	32
Español	39



NAVMAN

FCC Statement

Note: This equipment has been tested and found to comply with the limits for a Class B digital device, pursuant to Part 15 of the FCC Rules. These limits are designed to provide reasonable protection against harmful interference in a normal installation. This equipment generates, uses and can radiate radio frequency energy and, if not installed and used in accordance with the instructions, may cause harmful interference to radio communications. However, there is no guarantee that interference will not occur in a particular installation. If this equipment does cause harmful interference to radio or television reception, which can be determined by turning the equipment off and on, the user is encouraged to try to correct the interference by one or more of the following measures:

- Reorient or relocate the receiving antenna.
- Increase the separation between the equipment and receiver.
- Connect the equipment into an output on a circuit different from that to which the receiver is connected.
- Consult the dealer or an experienced technician for help.
- A shielded cable must be used when connecting a peripheral to the serial ports.

Contents

1 Operation	4
Alarms	4
Alarms On/Off	4
Shallow Alarm	4
Deep Alarm	4
2 Instrument Setup	5
Keel/Surface Offset	5
Transducer Setting	5
Units of Measure	5
3 Dual Station Operation	6
Master/Slave Selection	6
Linked or Separate Selection	7
4 Maintenance	7
5 Installation	8
Instrument Installation	8
6 Wiring	8
Appendix A - Specifications	9
Appendix B - Troubleshooting	10
Appendix C - How to contact us	47

Important

It is the owner's sole responsibility to install and use the instrument and transducer/s in a manner that will not cause accidents, personal injury or property damage. The user of this product is solely responsible for observing safe boating practices.

NAVMAN NZ LIMITED DISCLAIMS ALL LIABILITY FOR ANY USE OF THIS PRODUCT IN A WAY THAT MAY CAUSE ACCIDENTS, DAMAGE OR THAT MAY VIOLATE THE LAW.

This manual represents the DEPTH 2100 as at the time of printing. Navman NZ Limited reserves the right to make changes to specifications without notice.

Governing Language: This statement, any instruction manuals, user guides and other information relating to the product (Documentation) may be translated to, or has been translated from, another language (Translation). In the event of any conflict between any Translation of the Documentation, the English language version of the Documentation will be the official version of the Documentation.

Copyright © 2002 Navman NZ Limited, New Zealand. All rights reserved. NAVMAN is a registered trademark of Navman NZ Limited.

1 Operation

Whenever power is applied the depth sounder is active and water depth is displayed. If the sonar signal does not show a bottom the display will indicate "--". This can occur if the water is aerated or the maximum depth is exceeded. **Note:** *The maximum depth decreases as boat speed increases.*

Alarms

Two types of alarms can be set; the Deep Alarm and the Shallow Alarm. The Deep Alarm can be set as high as 184 metres (605 feet) while the Shallow Alarm can be set as low as 0.3 metre (1 foot).

Whenever the water depth is greater than the Deep Alarm setting and the alarm is enabled an alarm will sound. The alarm repeats two short beeps and alternates DAL and the water depth on the display.

Whenever the water depth is less than the Shallow Alarm setting and the alarm is enabled an alarm will sound. The alarm repeats a single long beep and alternates SAL and the water depth on the display.

Alarms On/Off

Alarm settings are saved in memory.

To turn the alarm on, press  (ON). An arrow on the lower right corner of the display will show (next to the Alarm Bell), to indicate that the alarms are on.



To turn the alarms off, press  (OFF). The arrow in the lower right corner will extinguish.



Note: *The arrow will flash if alarms are turned ON but the shallow alarm is individually set to OFF. See next section.*

Shallow Alarm





To set the shallow alarm:

1. Press  for three seconds. The display will show:





2. After a few seconds the display will indicate the current Shallow Alarm depth setting.



3. Use  and  to change the value. If either key is held depressed for more than one second the reading will increase or decrease rapidly.
4. When the alarm is set, exit by pressing both  and  simultaneously. Alternatively, if no keys are pressed for a period of 5 seconds the normal depth display will resume.



Press simultaneously to exit





Note: *If the reading is decreased to below 1.5 feet (or equivalent) the display will show OFF and the alarm will be disabled. The alarm can also be disabled by pressing both  and  for 5 seconds. The word OFF will be displayed but the alarm depth will be retained for future use.*

Deep Alarm

To set the deep alarm:



1. Press  for three seconds. The display will show:



2. After two seconds the display will indicate the current Deep Alarm depth setting.
3. Use  and  to change the value. If either key is held depressed for more than one second the reading will increase or decrease rapidly.
4. When the alarm is set, exit by pressing both  and  simultaneously. Alternatively, if no keys are pressed for a period of 5 seconds the normal depth display will resume.



Press simultaneously to exit

Note: *If the reading is increased one step above 600 feet (or equivalent) the display will show OFF and the alarm will be disabled. The alarm can also be disabled by pressing both  and  for 5 seconds. The word OFF will be displayed but the alarm depth will be retained for future use.*

2 Instrument Setup

Keel/Surface Offset

An offset may be automatically added to or subtracted from the depth reading to compensate for the location of the transducer. This allows the instrument to indicate the water depth relative to the bottom of the keel or the surface of the water.

To set the keel/surface offset:

1. Apply power while holding down 



Hold down during power up

2. When the unit is on, release . The display will indicate if the current offset is keel offset or waterline offset:



Hull Offset (Depth below the keel)







Surface Offset (Depth below the surface)

3. After 5 seconds the display will indicate the current offset.



Note: A negative offset is used to display depth below the keel and a positive offset is used to display depth below the surface.

4. Use  and  to change the value. If either key is held depressed for more than one second the reading will increase or decrease rapidly.
5. The offset can be programmed in 0.1 unit steps from -9.9 to 9.9 feet (or equivalent). When programmed for a negative offset, '-' will be indicated on the left hand side of the display.
6. To display depth below the keel enter the vertical distance between the bottom of the keel and the depth transducer as a negative value.
7. To display depth below surface enter the vertical distance from the waterline to the depth transducer as a positive number (no negative sign).

8. To exit this mode, press and hold both  and  simultaneously. Alternatively, if no keys are pressed for a period of 5 seconds normal depth display will resume.



Press simultaneously

The display will now indicate the current water depth.

Transducer Setting

A Transducer Setting is provided to allow the Depth 2100 to be used with different transducer types. The default setting (= 0.0) is used for most transducers.





Some transducers 'ring' after the sonar transmit pulse (just like hitting a bell). This ringing can be interpreted as an echo from a shallow bottom. The setting is used to increase the required level that shallow echoes must meet before they will be displayed.

If the Depth 2100 gives repeated false readings of 1.5 to 3 feet depth while in deep water the transducer setting should be increased. Adjust it upward by 0.5 at a time and retest. The range of values is -0.9 to +2.5. If the value is set too high it could cause erratic readings in shallow water.

Changing the Transducer Setting:

1. Apply power while holding down . The display will show either **HOF** or **SOF** for 7 seconds. Continue to hold the key down.
2. The display will show **tdr**.



3. Release the key.
4. After 2 seconds the display will show the Transducer Setting value eg **0.0**.
5. Use  and  to change the value.
6. To exit this mode, press and hold both  and  simultaneously.

Units of Measure

To select the displayed unit

1. Apply power while holding down .



Hold down during power up

- When the unit is on, release ∇ . The display will indicate the current display unit with:



Feet

Metres



Fathoms

- Use \blacktriangle and ∇ to change the value.
- To exit this mode, press and hold both \blacktriangle and ∇ simultaneously. Alternatively, if no keys are pressed for a period of 5 seconds normal depth display will resume.



Press simultaneously

The display will now indicate the current water depth in the selected display unit.

3 Dual Station Operation

Multiple Depth 2100 instruments can be installed on a single vessel. These instruments can be connected together and configured to operate in a dual station configuration. One instrument is designated as a master and all other instruments, connected to it, are configured as slaves. The master device is connected to the depth transducer and determines the water depth. This information is then displayed on all slave devices connected to it. Slave devices do not have transducers connected to them.

The slave devices can be configured to operate as fully functional NMEA repeaters where they display water depth, as displayed on the master device, and share common alarm settings and keel offset values. In this mode the common alarm settings can be changed or activated/deactivated from either the master or slave devices.

Alternatively, the slaves can be configured to operate as independent slaves. In this mode the slaves display the water depth received from the master, but have independent alarm settings and keel offset values.

Note: The instrument designated as the master device is the only instrument connected to the depth transducer.

Master/Slave Selection

To select the master/slave mode of operation:

- Apply power while holding down ∇ .



Hold down during power up

- When the unit is on. The display will indicate the current display unit:



example

- Continue to hold ∇ until the display indicates the current master/slave selection.



Master

Slave

- Use \blacktriangle and ∇ to change the selection.
- To exit this mode, press and hold both \blacktriangle and ∇ simultaneously. Alternatively, if no keys are pressed for a period of 5 seconds normal depth display will resume.



Press simultaneously

Note: If the data link is inadvertently broken then the display will alternate between -- and -SL.

Linked or Separate Selection

By default a dual station pair of Depth 2100 instruments automatically keep the following settings the same in both instruments:

- Alarms On/Off
- Alarm Values (Deep and Shallow)
- Keel Offset (*see note*)
- Units of measure (*see note*)

Example: Switching an alarm off on the slave instrument will also switch the alarm off on the master instrument. The reverse also applies, alarms changed on the master will be automatically changed in the slave instrument.

Note: The keel offset and units of measure should only be changed on the Master instrument.

If independent settings are required the link feature can be disabled.

To enable or disable the linked mode:

1. Apply power while holding down .



Hold down during power up

2. When the unit is on. The display will first indicate the current display unit:



Example

3. Continue to hold . The display will indicate the current master/slave selection.



Slave





4. Continue to hold  until the display indicates the current linked/separate selection.



Linked



Separate

5. Use  and  to change the selection.
6. To exit this mode, press and hold both  and  simultaneously. Alternatively, if no keys are pressed for a period of 5 seconds normal depth display will commence.



Press simultaneously

Note: This setup procedure applies to the master device and all slave devices. For separate operation all devices, including the master, must be set to Separate mode. Also, for linked operation all devices, including the master, must be set to Linked mode.

4 Maintenance

Your depth sounder is designed for years of trouble free operation assuming proper installation and care are provided. Following the operation and installation guidelines in this manual should ensure optimum performance of the instrument. In the unlikely event that the instrument shall fail to perform or shall need servicing, contact the dealer whom you purchased your Depth 2100 from.

5 Installation

Instrument Installation

The instrument can be easily installed in different types of instrument panels.

1. Select a suitable location for the instrument. When selecting the location for mounting, the following are recommended:
 - Controls of the instrument must be accessible to the user.
 - Electrical connections must be routed to the boat system as directly as possible, minimising the length of cable where practical.
 - Location should provide as much protection from the elements as possible.
 - The panel for mounting the instrument should be 3 mm to 19 mm (1/8 to 3/4 inch) thick.
 - The space behind the instrument panel must have a depth of at least 95 mm (3.75 inches).
2. Drill a 51 mm (2-inch hole) on the instrument panel in the selected location.
3. With the mounting bracket removed, insert the instrument into the hole until the back of the face plate is flush with the outside mounting wall.
4. Slide the bracket over the body of the instrument. Note: Orient the bracket in such a manner that it does not cover the buzzer.
5. Tighten the mounting nut until the bracket is secure.
6. Connect the power cord at the back of the instrument to a 12 V power supply which is active whenever the ignition switch is on. The red lead should be connected to the positive terminal of the power supply via a 1 amp fuse or a 1 amp circuit breaker.

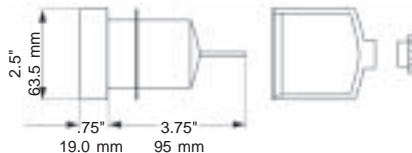

The black lead should be connected to the negative terminal.

7. Obtain the power from a 12 V source as directly as possible. Avoid power circuits which share loads with ignition, alternators, radio transmitters, etc. Excessive electrical noise associated with such devices may prevent the instrument from operating properly.
8. Connect the RCA phono plug on the transducer cable to the instrument. Extension cables are available from your NAVMAN dealer if the transducer cable is too short.

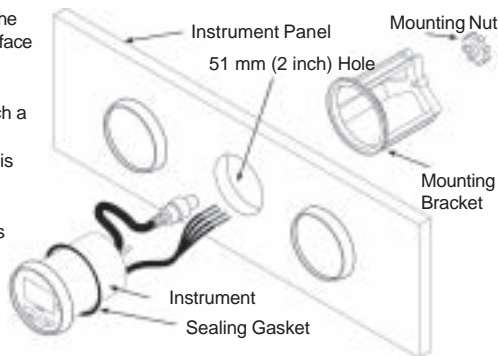

6 Wiring

- **Red (+) Terminal**
- **Black (-) Terminal**
- **Orange External Buzzer**

Use for optional external buzzer (use red (+) terminal to complete circuit). If unused then tape to avoid shorting.

- **Brown Data input/output**

Your Depth 2100 can be used as a repeater for another DPT or DBT NEMA depth sounder. If unused then tape to avoid shorting.

IMPORTANT: If unsure about wiring contact your nearest NAVMAN dealer.

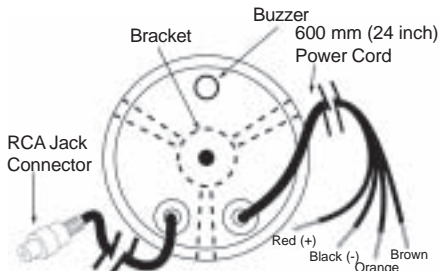

Appendix A - Specifications

- **Size**
Mount: 51 mm (2") diameter hole
Depth behind face plate: 95 mm (3.75") max.
Display: 3-character LCD
- **Colour**
Black bezel.
- **Backlighting**
Red coloured diffused lighting for display.
- **Water Integrity**
Front will withstand direct water spray.
- **Depth/Alarm Range**
2.0-600 feet
0.6-184 metres
0.3-100 fathoms
(to 9.9 in tenths)
- **Sensitivity**
Better than 0.05 mV RMS at 200 feet.
- **Transmit Power**
36 W RMS nominal at 13.6 V DC.
- **Transducer**
200 kHz 1900 pF/600 W parallel.
- **Display Updating**
1 second.
- **Operating Voltage**
9.5 V DC to 16.5 V DC.
- **Operating Temperature**
0°C to 50°C (32°F to 122°F).
- **Current Drain**
150 mA max, including internal buzzer.
- **Data Input/Output**
Single wire data output/Input.
Dual station mode outputs NMEA sentences.
Dual station accepts NMEA sentences. In the linked mode a dual station pair also transfer function settings eg. Alarm on/off.
- **NMEA Output**
DPT.
- **NMEA Input**
DPT and DBT.
- **External Buzzer Output**
12 V DC Buzzer, 100 mA max.
- **RF Interference**
<6 dB quieting on any marine radio channel (with 3 dB gain antenna) within one meter of the instrument. Complies with CE EMC standards EN50081-1 and EN50082-1.



Appendix B - Troubleshooting

No display:

1. Check DC power connections and DC polarity with voltmeter.
2. Check fuse.

No depth reading (--) at all depths:

1. Check transducer for growth or multiple coats of paint.
2. Check the transducer cable for cuts and sharp bends.
3. Check that the transducer connection behind the Depth 2100 is firm and free of corrosion.

Erratic readings while moored:

1. Check transducer for growth or multiple coats of paint.

Erratic readings while moving:

1. Cavitation (air) under the face of the transducer. Review installation and reinstall if necessary.

Erratic readings only while engine is running:

1. Re-route power and transducer cables away from engine, ignition wires and battery cables.
2. Add feed-through filter capacitor on the positive terminal of the ignition coil.
3. Add an alternator whine filter to alternator.
4. Replace spark plug wire with resistive type.

NORTH AMERICA**NAVMAN USA INC.**

18 Pine St. Ext.
 Nashua, NH 03060.
 Ph: +1 603 577 9600
 e-mail: sales@navmanusa.com

OCEANIA

New Zealand
Absolute Marine Ltd.
 Unit B, 138 Harris Road,
 East Tamaki, Auckland.
 Ph: +64 9 273 9273
 e-mail:
 navman@absolutemarine.co.nz

Papua New Guinea
Lawes Road Engineering
 Lawes Road, Konedobu
 PO Box 810
 Port Moresby
 Ph: +675 321 2122
 Email: loheng@online.net.pg

Australia
NAVMAN AUSTRALIA PTY
 Limited
 Unit 6 / 5-13 Parsons St,
 Rozelle, NSW 2039, Australia.
 Ph: +61 2 9818 8382
 e-mail: sales@navman.com.au

SOUTH AMERICA

Argentina
Costanera UNO S.A.
 Av Presidente R Castillo y
 Calle 13
 1425 Buenos Aires, Argentina.
 Ph: +51 11 4312 4545
 e-mail:
 purchase@costanerauno.com.ar
 Website:
 www.costanerauno.ar

Brazil
REALMARINE
 Estrada do Joa 3862,
 CEP2611-020,
 Barra da Tijuca, Rio de Janeiro,
 Brasil.
 Ph: +55 21 2483 9700
 e-mail:
 vendas@marinedepot.com.br

Equinatic Com Imp Exp de
Equip Nauticos Ltda.
 Av. Diario de Noticias 1997 CEP
 90810-080, Bairro Cristal, Porto
 Alegre - RS, Brasil.
 Ph: +55 51 3242 9972
 e-mail:
 equinatic@equinatic.com.br

ASIA

China
Peaceful Marine Electronics Co. Ltd.
 Hong Kong, Guangzhou,
 Shanghai, Qindao, Dalian.
 E210, Huang Hua Gang Ke Mao
 Street, 81 Xian Lie Zhong Road,
 510070 Guangzhou, China.
 Ph: +86 20 3869 8784
 e-mail: sales@peaceful-marine.com
 Website: www.peaceful-marine.com

India
Access India Overseas Pvt
 A-98, Sector 21, Noida, India
 Ph: +91 120 244 2697
 Email: vkapil@del3.vsnl.net.in

Indonesia
Polytech Nusantara
 Graha Paramita 2nd Floor
 Jln Denpasar Raya Blok D2
 Kav 8 Kuningan, Jakarta 12940
 Tel: 021 252 3249

Korea
Kumhomarine Technology Co., Ltd.
 #604-842, 2F, 1118-15,
 Janglim1-Dong, Saha-Gu
 Busan, Korea
 Ph: +82 51 293 8589
 e-mail: info@kumhomarine.com
 Website: www.kumhomarine.com

Maldives
Maizan Electronics Pte. Ltd.
 8 Sosunmagu Male
 Ph: +960 78 2444
 Email: ahmed@maizan.com.mv

Singapore
RIQ PTE Ltd.
 81, Defu Lane 10, Hah Building,
 #02-00 Singapore 539217
 Ph: +65 6741 3723
 e-mail: riq@postone.com

Taiwan
Seafirst International Corporation
 No.281, Hou-An Road
 Chien-Chen Dist.
 Kaohsiung, Taiwan R.O.C.
 Ph: +886 7 831 2688
 e-mail: seafirst@seed.net.tw

Thailand
Thong Electronics (Thailand)
 Company Ltd.
 923/588 Thaprong Road,
 Mahachai,
 Muang, Samutsakhon 74000,
 Thailand.
 Ph: +66 34 411 919
 e-mail: thonge@cscoms.com

Vietnam
Haidang Co. Ltd.
 16A/AIE, Ba thang hai St.
 District 10, Hochiminh City.
 Ph: +84 8 86321 59
 e-mail: sales@haidangvn.com
 Website: www.haidangvn.com

MIDDLE EAST

Lebanon and Syria
Letro, Balco Stores,
 Moutran Street, Tripoli VIA Beirut.
 Ph: +961 6 624512
 e-mail: balco@cyberia.net.lb

United Arab Emirates
Kuwait, Oman, Iran & Saudi Arabia
 Abdullah Moh'd Ibrahim
 Trading, opp Creak Rd.
 Baniyas Road, Dubai.
 Ph: +971 4 229 1195
 e-mail: mksq99@email.com

AFRICA

South Africa
Pertec (Pty) Ltd Coastal,
 Division No.16 Paarden Eiland Rd.
 Paarden Eiland, 7405
 Postal Address: PO Box 527,
 Paarden Eiland 7420
 Cape Town, South Africa.
 Ph: +27 21 511 5055
 e-mail: info@kfa.co.za

EUROPE

France, Belgium and
Switzerland
PLASTIMO INTERNATIONAL
 15, rue Ingénieur Verrière,
 BP435,
 56325 Lorient Cedex.
 Ph: +33 2 97 87 36 36
 e-mail: plastimo@plastimo.fr
 Website: www.plastimo.fr

Germany
PLASTIMO DEUTSCHLAND
 15, rue Ingénieur Verrière
 BP435- 56325 Lorient Cedex.
 Ph: +49 6105 92 10 09
 +49 6105 92 10 10
 +49 6105 92 10 12

e-mail:
 plastimo.international@plastimo.fr
 Website: www.plastimo.de

Italy
PLASTIMO ITALIA
 Nuova Rade spa, Via del Portasso 5
 I-16015 CASELLA SCRIVIA (GE).
 Ph: +39 1096 8011
 e-mail: info@nuovarade.com
 Website: www.plastimo.it

Holland
PLASTIMO HOLLAND BV.
 Industrieweg 4-6,
 2871 RP SCHOONHOVEN.
 Ph: +31 182 320 522
 e-mail: info@plastimo.nl
 Website: www.plastimo.nl

United Kingdom
PLASTIMO Mfg. UK Ltd.
 School Lane - Chandlers Ford
 Industrial Estate,
 EASTLEIGH - HANTS SO53 ADG.
 Ph: +44 23 8026 3311
 e-mail: sales@plastimo.co.uk
 Website: www.plastimo.co.uk

Sweden, Denmark or Finland
PLASTIMO NORDIC AB.
 Box 28 - Lundenvägen 2,
 47321 HENAN.
 Ph: +46 304 360 60
 e-mail: info@plastimo.se
 Website: www.plastimo.se

Spain
PLASTIMO ESPAÑA, S.A.
 Avenida Narcis Monturiol, 17
 08339 VILASSAR DE DALT,
 (Barcelona).
 Ph: +34 93 750 75 04
 e-mail: plastimo@plastimo.es
 Website: www.plastimo.es

Portugal
PLASTIMO PORTUGAL
 Avenida de India N°40
 1300-299 Lisbon
 Ph: +351 21 362 04 57
 e-mail:
 plastimo@siroco-nautica.pt

Other countries in Europe
PLASTIMO INTERNATIONAL
 15, rue Ingénieur Verrière
 BP435
 56325 Lorient Cedex, France.
 Ph: +33 2 97 87 36 59
 e-mail:
 plastimo.international@plastimo.fr
 Website: www.plastimo.com

REST OF WORLD /
MANUFACTURERS
Navman NZ Limited
 13-17 Kawana St. Northcote.
 P.O. Box 68 155 Newton,
 Auckland, New Zealand.
 Ph: +64 9 481 0500
 e-mail:
 marine.sales@navman.com
 Website: www.navman.com

Made in New Zealand
MN000205A

Lon 174° 44.535'E

Lat 36° 48.404'S

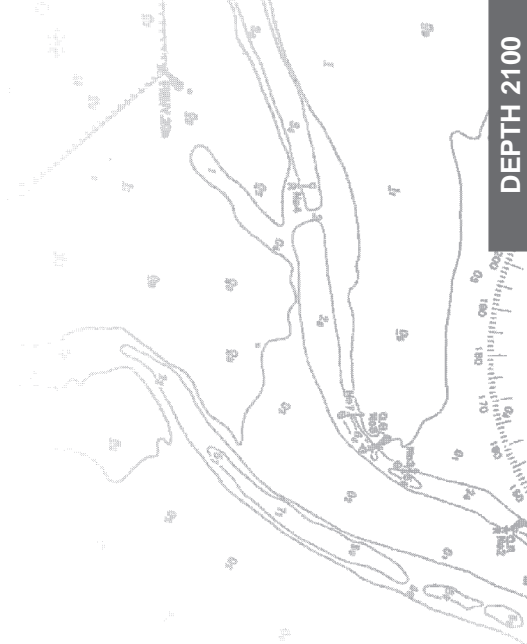

DEPTH 2100

NAVMAN

FC CE