

Fish 4432 / 4433

F I S H F I N D E R S

Installation and Operation Manual

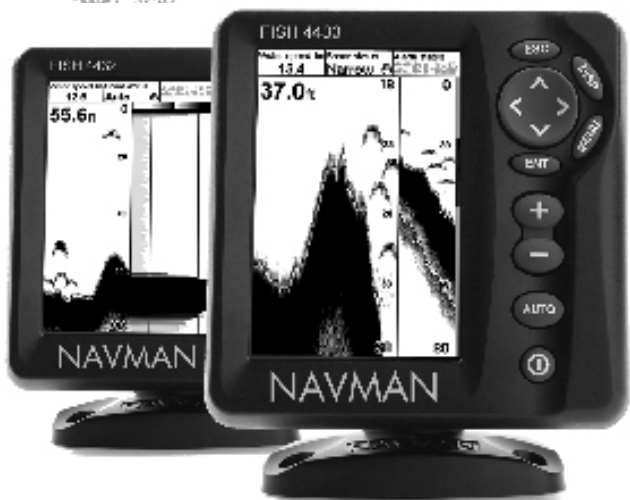

NAVMAN

Contents

1 Introduction	5
1-1 Benefits of the FISH 4432/4433	5
1-2 How the FISH 4432/4433 works	6
2 Basic Operation	6
3 Setting up the FISH 4432/4433	8
3-1 Setup > System	10
3-2 Setup > Sonar	10
3-3 Setup > Fuel (available on 4433 only)	11
3-4 Setup > Logs	12
3-5 Setup > Alarms	13
3-6 Setup > Units	13
3-7 Setup > Comms (4433 only)	14
3-8 Setup > Calibrate	14
4 Using the FISH 4432/4433	16
4-1 Interpreting the display	16
4-2 Single and Dual frequency fishfinding	18
4-3 Fish detection and display	20
4-4 Gain	21
4-5 Range	22
5 The Displays	23
5-1 Sonar display	23
5-2 Sonar Zoom display	24
5-3 Sonar Bottom display	25
5-4 Sonar 83/200 display	25
5-5 Sonar A-Scope display	25
5-6 A-Scope perspective view	26
5-7 Fuel display (4433 only)	26
5-8 Data display	27
5-9 About display	27
6 Installation and Maintenance	28
Wiring Options	28
6-1 What comes with this product?	30
6-2 Options and Accessories	30

6-3 Mounting and removing the display unit	30
6-4 Systems of several instruments (4433 Only)	31
6-5 Cleaning and maintenance	32
Appendix A - Specifications	33
Appendix B - Dimensions	34
Appendix C - Troubleshooting	34

Important

It is the owner's sole responsibility to install and use the instrument and transducers in a manner that will not cause accidents, personal injury or property damage. The user of this product is solely responsible for observing safe boating practices.

NAVMAN NZ LIMITED DISCLAIMS ALL LIABILITY FOR ANY USE OF THIS PRODUCT IN A WAY THAT MAY CAUSE ACCIDENTS, DAMAGE OR THAT MAY VIOLATE THE LAW.

Governing Language: This statement, any instruction manuals, user guides and other information relating to the product (Documentation) may be translated to, or has been translated from, another language (Translation). In the event of any conflict between any Translation of the Documentation, the English language version of the Documentation will be the official version of the Documentation.

This manual represents the FISH 4432/4433 as at the time of printing. Navman NZ Limited reserves the right to make changes to specifications without notice.

Copyright © 2005 Navman NZ Limited, New Zealand, all rights reserved. NAVMAN is a registered trademark of Navman NZ Limited.

1 Introduction

Congratulations on choosing a Navman fish-finder. For maximum benefit, please read this manual carefully before installation and use.

This manual describes how to install and set up the FISH 4432/4433 and the associated dual-frequency transom transducer. (If a through hull transducer is used, refer to the Installation Instructions supplied with that transducer.)

This manual also explains how to operate the FISH 4432/4433 effectively and provides troubleshooting information and performance tips.

Important

It is vital to the performance of the fishfinder that the transducer is installed in the best location. Please follow the installation instructions very carefully.

1-1 Benefits of the FISH 4432/4433

The FISH 4432/4433 is a high quality, dual-frequency sonar fishfinder that is supplied with a dual-frequency transducer. It uses a 16 level greyscale FSTN display for easy daylight viewing that can be dimmed for night fishing. The bracket mounting option also allows the fishfinder to be tilted and swivelled for optimum viewing.

The dual frequency capability enables the FISH 4432/4433 to operate and display:

- At a high frequency of 200 kHz.
- At a low frequency of 83 kHz.
- Both frequencies side-by-side on a split display.
- Both frequencies combined together into a single display.

This capability, combined with a variable power output of up to 250 watts, ensures that the FISH 4432/4433 operates effectively in shallow and deep water.

The FISH 4432/4433 can detect the bottom to a depth of 750 feet (230 metres) depending on the clarity of the water, the ultrasonic frequency chosen and the type of transducer used.

The Navman fishfinder can be used to find fish, to locate features on the bottom such as reefs or wrecks and to help recognize favourite fishing spots from the bottom profile.

The Navman fishfinder can also assist with navigation by providing depth information to

help identify the depth contours marked on charts. The FISH 4432/4433 is particularly suited to work with the TRACKER 5430/5380.

The two instruments can be connected together using either NavBus or NMEA, so they can share data. (only applies to FISH 4433)

IMPORTANT NOTE ON USE. While any fishfinder can be used as an aid to navigation, accuracy can be limited by many factors, including the location of the transducer. It is the user's responsibility to ensure the Navman fishfinder is installed and used correctly.

With the optional fuel kit, the FISH 4433 also becomes a sophisticated and easy-to-use fuel computer.

All of the Navman 4000 Series fishfinders use new proprietary SBN-// Technology for sonar processing to improve Signal enhancement, Bottom recognition and Noise rejection.

SBN-// Technology uses digital adaptive filter algorithms to enhance all returned signals. At the same time, SBN-// Technology uses active noise control to reject interference, which can often be mistaken by fishfinders for true returns.

Using SBN-// Technology, the Navman fishfinder analyses the reflections from each pulse, filters false returns and displays what is in the water under the boat. See section 4-1 Interpreting the display, for more information.

1-2 How the FISH 4432/4433 works

The FISH 4432/4433 has two parts:

- the transducer attached to the hull
- the display unit.

The transducer generates an ultrasonic pulse (sound that is above the hearing range of the human ear), which travels down towards the bottom at a speed of about 4800 ft/sec (1463 m/sec), spreading out into a cone shape.

When the pulse meets an object, such as a fish or the bottom, it is partly reflected back up towards the boat as an echo. The depth of the object or bottom is calculated by the FISH 4432/4433 by measuring the time taken between sending a pulse and receiving the echo. When an echo has been returned, the next pulse is sent.

The FISH 4432/4433 converts each echo into an electronic signal, displayed as a vertical

line of pixels. The most recent echo appears on the extreme right of the display, with the older echoes being scrolled towards the left, eventually disappearing off the display.

The scroll speed depends upon the water depth and scroll speed setting. See section 3-2 Setup > Sonar and section 4-1 Interpreting the display, for more information.

The appearance of echoes displayed are affected by:

- the fishfinder settings (frequency selected, range and gain settings)
- echoes (different fish types, different bottom types, wrecks and seaweed)
- noise (water clarity and bubbles).

See section 4-1 Interpreting the display, for more information.

2 Basic Operation

Key Names



ESC

If a menu is not displayed then go to the sonar display. If a menu is displayed then cancel any changes and return to the previous menu.

DISP

Shows the Display menu.

<, >

Cursor keys move the selection highlight and change settings.

^, v

MENU

Press to show the Options menu on a display; press again to show the Setup menu.

ENT

Confirms any changes or from a sonar display shows the Gain controls.

+

Increases the Range.

-

Decreases the Range.

AUTO

Select fishing/cruising or manual operating mode

ⓘ

Powers On and Off; shows the Backlight control.

Power On / Auto Power

Press **⏻** to turn the fishfinder on.

If the fishfinder is wired for auto power, it turns on automatically whenever the boat's ignition is turned on. This ensures that the engine hours counter and optional fuel functions are activated. *A title display appears briefly. This is followed automatically by the Installation menu the first time the fishfinder is switched on. Use this menu to specify the language (see section 3-1 Setup > System) and units (see section 3-6 Setup > Units).*

At all other times, the title display is followed by the display that was used most recently.

If the transducer is not connected, the message: `Enter simulate mode?` will appear. Press **<** or **>** to switch between `Yes`, `No` or `Never`. (If the transducer was not intentionally disconnected, turn off the fishfinder and refer to the section on Troubleshooting in Appendix B.)

Power Off

To turn the fishfinder off, hold **⏻**. A countdown box appears. Continue to hold **⏻** for 3 seconds until the fishfinder turns off.

Note: If the unit is wired for Auto Power (section 6-5 Wiring options) the fishfinder can be turned off only when the boat's ignition is turned off.

Backlight Adjustment

To change the backlight level:

1. Press **⏻** briefly to show the display controls.
2. The display and keys are backlit, with a choice of 16 brightness levels.
Press **<** to dim or **>** to brighten.
3. To change contrast:
 - i Press **∨**
 - ii Press **<**, **>** to adjust
4. Press **ENT** to save settings.
5. Press **ESC** to exit.

Press **⏻** twice to return to the maximum backlight setting and default contrast.

Press **ENT** to confirm the selection and the startup sequence will continue.

Key Operation

The fishfinder is operated through menus.

To select a menu item:

1. Press **DISP** or **MENU**
2. Press **∧** or **∨** to move the highlight to the item.
3. Press **ENT** to select the item.

To change a number, word or setting:

1. Use the cursor keys, **<**, **∧**, **∨**, **>** to highlight the number, word or setting and to make the change(s).
2. Press **ENT** to confirm; **ESC** to cancel.

Menu Note:

Some menu items in the FISH 4432/4433 menu's utilize checkboxes.

If the box is selected or 'checked' (contains a check or tick), then that function is enabled or ON.

If the box is de-selected or 'un-checked' (does not contain a check or tick), then that function is disabled or OFF.

To select or de-select a checkbox, highlight the menu item and press **ENT**.

Setup	
System	▶
Sonar	▶
Fuel	▶
Logs	▶
Alarms	▶
Units	▶
Comms	▶
Calibrate	▶
Simulate	<input type="checkbox"/>
Simulate	<input checked="" type="checkbox"/>

Simulate Mode

An internal simulator allows users to learn how to operate the fishfinder off the water.

In Simulate mode the word `Simulate` flashes on the bottom of the display. The fishfinder generates data so that all the main displays appear to be operational.

Use `Setup > Simulate` as follows:

1. Press **MENU** twice to show the Setup menu.
2. Highlight `Simulate`.
3. Press **ENT** to select or de-select.

Manual, Fishing and Cruising Modes

Press **AUTO** to select one of the three following operating modes:

- **Cruise mode.** Use this when on the move. The FISH 4432/4433 prominently displays the water depth and automatically adjusts Range and Gain so that the bottom trace is displayed. Depth is displayed in large digits.
- **Fishing mode.** Use this when fishing. The FISH 4432/4433 prominently displays fish, the bottom profile, wrecks, rocks and all the details that help to find fish. Gain and Range are optimized automatically, increasing the sensitivity and fishfinding ability.
- **Manual mode.** Use this to fine-tune the fishfinding ability of the FISH 4432/4433. Best results are often achieved in manual mode, but practice and experience are required to obtain the optimum settings for different conditions. Gain, gain threshold and pulse power can all be adjusted. Manual mode stores the most recent settings, so these do not have to be reset each time manual mode is selected.

3 Setting up the FISH 4432/4433

Press **MENU** twice, to show the `Setup` menu, then select a particular option using the \wedge or \vee cursor keys. (Section 2 Basic Operation, describes the basic use of keys.)

The `Setup` menu and options are summarized below. **The factory default settings are shown where applicable.**

Each `Setup` menu option is explained in the following sections.

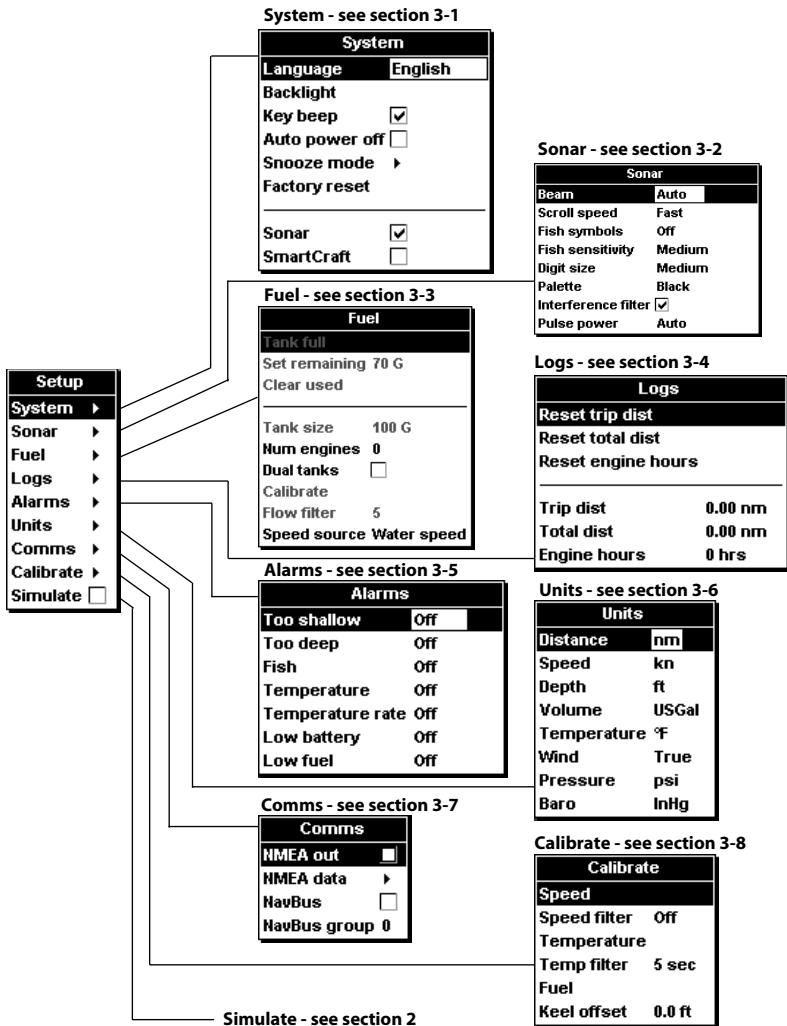

3-1 Setup > System

Press **MENU** once or more until the Setup menu is displayed, then select **System**:

System	
Language	English
Backlight	
Key beep	<input checked="" type="checkbox"/>
Auto power off	<input type="checkbox"/>
Snooze mode	▶
Factory reset	

Sonar	<input checked="" type="checkbox"/>
SmartCraft	<input type="checkbox"/>

Language

Select the language for the displays. The options are: English, Italian, French, German, Spanish, Dutch, Swedish, Portuguese, Finnish Greek and Croatian.

Tip: In case you can't read the current language, the language setting is found at the top of the system menu.

Backlight

Select this option to adjust backlighting and contrast controls.

Key beep

Enables or disables the beep when a key is pressed.

Auto power off

Select to have the fishfinder power off automatically every time the boat's ignition is switched off. This applies only if the display unit is wired for Auto Power. See section 6-5 Wiring Options.

Snooze Mode

This power saving option slows the sounding rate (time between each ultrasonic pulse) to a user specified interval from 5 minutes to 2 hours. The fishfinder appears to turn off, however all alarms operate normally. To return to normal operation, press Power **ⓘ** button. Ideal to be used as an anchor alarm.

Factory reset

This option returns all of the fishfinder settings (except the language) to the default factory settings shown in section 3 Setting up the FISH 4432/4433.

A warning box asks: *Are you sure?* Select **Yes** and press **ENT** to confirm.

Sonar (FISH 4433)

Select to enable sonar functions. Deselect if the unit is to be used as a SmartCraft only display.

SmartCraft (FISH 4433)

Select to enable SmartCraft functions. SmartCraft is only available with certain Mercury engines, and requires an optional SmartCraft Gateway.

3-2 Setup > Sonar

Press **MENU** once or more until the Setup menu is displayed, then select **Sonar**:

Sonar	
Beam	Narrow
Scroll speed	Fast
Fish symbols	Off
Fish sensitivity	Medium
Digit size	Medium
Palette	High contrast

Beam

There is a choice of Narrow (200kHz), Wide(83kHz), Mixed and Auto. For more info about selecting a suitable frequency for water conditions, see section 4-2 Single and Dual Frequency Fishfinding.

Scroll speed

Use this to set the scroll speed on the display. There is a choice of: *Very Fast*, *Fast*, *Medium*, *Slow* and *Pause*. The depth of the water also affects the speed of the display.

Faster scroll speeds combined with a slow boat speed (typically between 2 and 6 knots) shows the most fish detail. *Medium* or *Slow* scroll speeds result in sonar information being displayed over a longer period, but with less detail. See Section 4-1 Interpreting the display, for more information.

Fish symbols

These appear only in the main sonar displays. Fish symbols can be shown in three ways:

- As a fish symbol (*Symbol*).
- As a fish symbol with the depth (*Symbol+depth*). The depth is shown beside the fish symbol.
- As a depth (*Depth*). The depth is shown above where the fish was detected
- Switched off (*Off*) so that echoes are not converted to fish symbols but are displayed directly.

See section 4-3 Fish detection and display, for more information about fish symbols.

3-3 Setup > Fuel (available on 4433 only)

These features can be used only when the optional single or twin engine fuel kit has been installed.

Press **MENU** once or more until the *Setup* menu is displayed, then select *Fuel*:

It is recommended that the fuel tank capacity is measured by draining the fuel tank, then filling it to capacity. After filling, note the reading from the fuel dispenser's gauge.

Note: *Beware of air pockets, especially in underfloor tanks.*

Warning

Navman fuel kits are only suitable for petrol/gasoline engines. Fuel consumption can change drastically depending upon the boat loading and the sea conditions. Always carry adequate fuel for the journey, plus a reserve.

Fish sensitivity

Use this function to adjust the minimum fish detection level. Select *Low* to reject noise and small fish. Select *High* to detect maximum number of fish.

Digit size

Use this to remove or change the size of the depth display on the sonar displays. There is a choice of: *Small*, *Medium* and *Large*.

Palette

Use this to select a color palette. Each color within the palette represents a different echo strength, as shown on the sonar displays.

There is a choice of three color palettes: *Black*, *White* and *High Contrast*.

Interference filter

This filters the echo signal to reduce high-level, spiky interference, such as engine noise and makes small fish harder to see.

Select to add filter.

Pulse power

This can be used to specify the power output of the transmitted ultrasonic pulse. Low power output conserves the boat's battery, but only works in shallow water.

There is a choice of *Auto*, *Low*, *Medium* or *High*. The *Auto* setting is recommended.

Tank full

Select *Tank full* each time the fuel tank(s) are completely refilled. When asked *Are you sure?* select *Yes*. Otherwise, the reading on the *Fuel* display (see section 5-6 Fuel Display) and the *Low Fuel Alarm* (see section 3-5 Setup > Alarms) are meaningless.

Set remaining

Before doing a partial refill of the tank or removing fuel manually from the tank (for example, by siphoning it off):

1. Note the *Remaining* reading on the *Fuel* display.
2. Note how much fuel is added or removed.
3. Calculate how much fuel is now in the tank.
4. Select *Set remaining* and update the reading.

It is essential to do this whenever some fuel is added or removed. Otherwise, the reading on the Fuel display (see section 5-6 Fuel Display) and the Low Fuel Alarm (see section 3-5 Setup > Alarms) are meaningless.

Clear used

Select **Clear used** to set **Used** (the amount of fuel used) to zero. Do this to start measuring the amount of fuel used over a certain time or distance.

When asked **Are you sure?** select **Yes**.

Tank size

Enter the capacity of the fuel tank.

Flow filter

Most engines do not draw fuel from the tank at a steady rate. To give a stable fuel flow reading, the fishfinder calculates the flow value(s) by taking several measurements and averaging them. Use the **Flow filter** to set the period over which the fuel flow is averaged.

The **Flow filter** can be set from 0 to 30 seconds. Use the lowest value which gives a stable flow. Usually a value of 5 to 10 seconds will give a satisfactory result for two-stroke carburettor engines. Fuel injected or four-stroke engines may require a larger value.

3-4 Setup > Logs

Press **MENU** one or more times until the **Setup** menu is displayed, then select **Logs**:

Logs	
Reset trip dist	
Reset total dist	
Reset engine hours	
<hr/>	
Trip dist	0.00 nm
Total dist	0.00 nm
Engine hours	0 hrs

This setting affects the **Fuel flow** and **Fuel economy** reading on the Fuel display (see section 5-6 Fuel display) but it does not affect the **Fuel used** reading.

Speed Source

Select speed input from water speed transducer or external GPS source (an external GPS source must be connected to the Fishfinder via NavBus – see section 3-7 Setup > Comms.)

Num engines

Select the number of engines to 0, 1 or 2. If 0 is selected the fuel features are turned off.

Calibrate

See section 3-8 Setup > Calibrate, for information about calibrating the fuel transducer(s).

The values can be changed independently of each other. These log values are saved when the unit is turned off.

Reset trip dist

This resets the trip distance to zero.

Reset total dist

This option resets the total distance to zero.

Reset engine hours

Use this option to reset the engine hours to zero. This can be useful after an engine service or to count the engine hours between service intervals.

3-5 Setup > Alarms

Press **MENU** one or more times until the Setup menu is displayed, then select **Alarms**:

Alarms	
Too shallow	Off
Too deep	Off
Fish	Off
Temperature	Off
Temperature rate	Off
Low battery	Off
Low fuel	Off

Trigger settings can be defined to suit the boat and individual preferences as follows:

Alarms can be set (enabled) to automatically detect certain conditions, such as the water being too shallow. Alarms that are enabled are shown as black icons in the Alarm status box on the sonar displays.

When an enabled alarm is triggered, the beeper sounds, an alarm message is displayed and the alarm status icon flashes.

Press **ENT** or **ESC** to acknowledge the alarm, stop the beeper and close the alarm window. This does not disable the alarm.

Alarms automatically re-enable

The **Too shallow**, **Too Deep** and **Low battery** alarms automatically re-enable when the value moves outside the alarm trigger setting.

The **Temperature** alarm automatically re-enables when the temperature is more

Symbol	Alarm Name	Beeper Cycle	Alarm condition is met when the:
	Too shallow	1/2 sec	Depth is less than the alarm trigger value
	Too deep	1/2 sec	Depth is greater than the alarm trigger value
	Fish	1 short beep	Echo matches the profile of a fish
	Temp.	1/2 sec	Temperature equals the alarm trigger value
	Temp. rate	1/2 sec	Rate of change of temperature equals the alarm trigger value
	Low battery	1/2 sec	Battery voltage is less than the alarm trigger value
	Low fuel*	1/2 sec	Fuel remaining equals the alarm trigger value *Only 4432

than 0.45°F (0.25°C) above or below the alarm trigger setting.

The **Temperature rate** alarm automatically re-enables when the rate of temperature change falls below the trigger setting by more than 0.2°F (0.1°C) per minute.

Flashing light and/or external beeper

If a secondary alarm indicator is required, a flashing light and/or external beeper can be installed. These can be positioned anywhere suitable on the boat. See section 6-5 Wiring options.

3-6 Setup > Units

Press **MENU** one or more times until the Setup menu is displayed, then select **Units**:

Units	
Distance	nm
Speed	kn
Depth	ft
Volume	USGal
Temperature	°F
Wind	True
Pressure	psi
Baro	InHg

The default units are shown in this example.

Distance

Select from:

- nm (nautical miles)
- mi (miles)
- km (kilometres)

Baro

- InHg (Inches of mercury)
- Mb (Millibars) - sometimes called kPa

Speed

Select from:

- kn (knots)
- mph (miles per hour)
- kph (kilometres per hour)

Wind

- True
- Apparent

Depth

Select from:

- ft (feet)
- m (metres)
- fa (fathoms)

Pressure

- kPa
- psi

Fuel

Select from:

- Litres
- USGal (US gallons)
- ImpGal (Imperial Gallons)

Temperature

Select either:

- °F (Fahrenheit)
- °C (Celsius)

3-7 Setup > Comms (4433 only)

Use this feature when the FISH 4432/4433 is connected to other Navman instruments through NavBus or any compatible NMEA instrument.

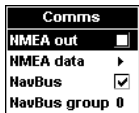

Press **MENU** once or more until the **Setup** menu is displayed, then select **Comms**:

NMEA Out

NMEA is generally used with third party instruments. Select to transmit NMEA sentences (see Appendix A - Specifications).

NMEA data

Use this to specify which NMEA sentences will be transmitted (see Appendix A - Specifications and section 5-7 Data display, for information about how to display NMEA data).

NavBus

NavBus is the preferred method for connecting the FISH 4433 to other Navman instruments. Select if the instruments are connected using NavBus.

NavBus Group

Use this when a group of Navman instruments are connected together using NavBus, to specify a group of instruments for backlighting, if required. Then, if the backlight setting on one instrument in the group is adjusted, the other instruments change automatically. Otherwise, select 0.

3-8 Setup > Calibrate

Press **MENU** once or more until the **Setup** menu is displayed, then select **Calibrate**:

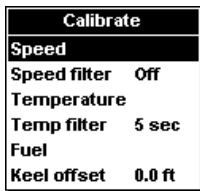

The fuel options can be calibrated only when the optional single or twin engine kit is installed on petrol/gasoline engines.

Speed*

Calibration may be required because different hull shapes have different flow characteristics.

Obtain an accurate measurement of the boat's speed from a GPS receiver; or by following another boat travelling at a known speed; or by making a timed run over a known distance.

Note: for accurate calibration:

- The speed from a GPS receiver should be greater than 5 knots.
- The speed from another paddlewheel transducer should be between 5 and 20 knots.
- Best results are achieved in calm conditions where there is minimal current (best at high or low tide).

Use the cursor keys to display the speed readout box, then increase or decrease the readout to match the independent speed value.

Speed Filter*

Increase this setting to stabilise an erratic speed reading. Decrease to improve reading responsiveness. The speed filter can be set from 0 to 30 seconds.

* only available on 4433

Temperature

The factory settings should be sufficiently accurate for normal usage. To calibrate the temperature readout, first measure the water temperature with a thermometer known to be accurate.

Use the cursor keys to display the temperature readout box, then increase or decrease the value to match the measured temperature. The temperature can be set from 32° to 99.9°F (0° to 37.7°C) with a resolution of 0.1° unit.

To change the units between °F (Fahrenheit) or °C (Celsius), see section 3-6 Setup > Units.

Temp filter

Increase this setting to stabilise an erratic temperature reading. Decrease to improve reading responsiveness. The temperature filter can be set from 0 to 30 seconds.

Fuel

Warning:

Extreme precautions must be observed when carrying out this procedure.

Failure to do so could create hazardous conditions that can cause serious personal or property damage.



Calibrating the fuel usage can improve the accuracy of fuel measurements.

Twin engine installations require each fuel transducer to be calibrated. This can be done at the same time with two portable tanks or at different times using one portable tank.

Calibrating the fuel transducer(s) requires accurate measurement of the fuel consumption. This is best done using a small portable tank. At least 4 gallons (15 litres) of fuel should be used to ensure an accurate calibration.

It is often very difficult to fill underfloor tanks to the same level twice due to air pockets, so the more fuel used, the more accurate the calibration.

To calibrate the fuel transducer(s), perform the following steps:

1. Record the level of the fuel in the tank(s).

2. Connect the portable tank(s) to the engine through the fuel transducer(s).
3. Run the engine at normal cruising speed until at least 4 gallons (15 litres) of fuel has been used per engine.
4. Check the actual amount of fuel used per engine by refilling the portable tank(s) to the original level and noting the reading(s) from the fuel dispenser's gauge.
5. Select **Fuel**. Use the cursor keys to change the reading for each engine to match that on the fuel dispenser's gauge.
6. Press **ENT** when the reading is correct.

Note: If the fuel calibration options appear to give erroneous readings after a while, first check that the fuel sensor has been installed correctly according to the installation instructions supplied with it. Then see Appendix B - Troubleshooting.

Keel offset

Keel offset is a depth correction representing the vertical distance between the depth transducer and the location from which the depth is to be measured.

Enter a **positive** keel offset value when the transducer is located below the water surface but the total depth is required.

Enter a **negative** keel offset value when the depth below the deepest part of the boat is required (such as the keel, the rudder or the propeller) and the transducer is located closer to the water surface.

Use the cursor keys to select **Keel offset**, then press > to display the Keel offset box.

Use the ^ or v cursor keys to adjust the value.

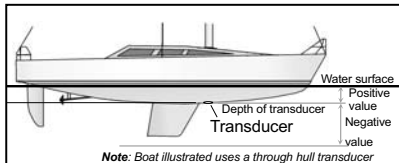

4 Using the FISH 4432/4433

This section explains how to interpret the sonar displays, when and why to use the different frequencies and how fish are detected and displayed.

4-1 Interpreting the display

The sonar displays do not show a fixed distance travelled by the boat; rather, they display a history, showing what has passed below the boat during a certain period of time.

The history of the sonar signal displayed depends on the depth of the water and the scroll speed setting.

In shallow water, the echoes have a short distance to travel between the bottom and the boat. In deep water, the history moves across the display more slowly because the echoes take longer to travel between the bottom and the boat. For example, when the scroll speed is set to **Fast**, at depths over 600ft it takes about 2.5 minutes for each vertical line of pixels to move across the display, whereas at 20ft it takes only about 4-5 seconds.

The scroll speed can be set by the user to display either a longer history with less fish information or a shorter history with more fish details. See section 3-2 Setup > Sonar.

If the boat is anchored, the echoes all come from the same area of bottom. This produces a flat bottom trace on the display.

The screen shot shows a typical sonar display with the Fish symbols turned **Off**.

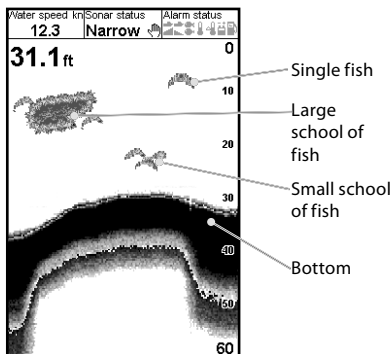

It also describes Gain and Range and shows examples of some of the different sonar displays. Also see section 1-2 How the FISH 4432/4433 works.

Strength of echoes

The colors indicate differences in the strength of the echo. The strength varies with several factors, such as the:

- Size of the fish, school of fish or other object.
- Depth of the fish or object.
- Location of the fish or object. (The area covered by the ultrasonic pulse is a rough cone shape and the echoes are strongest in the middle.)
- Clarity of water. Particles or air in the water reduce the strength of the echo.
- Composition or density of the object or bottom.

Note: Planing hulls at speed produce air bubbles and turbulent water that bombard the transducer. The resulting ultrasonic noise may be picked up by the transducer and obscure the real echoes.

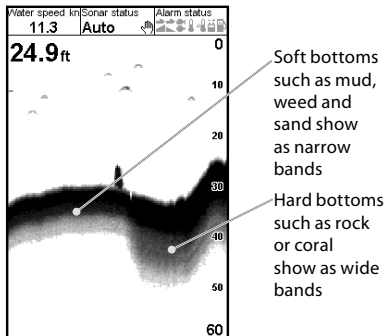

Bottom types

Mud, weed and sandy bottoms tend to weaken and scatter the sonar pulse, resulting in a weak echo. Hard, rocky or coral bottoms reflect the pulse, resulting in a strong echo. See section 5-3 Sonar Bottom display.

Frequency and cone width

The pulse generated by the FISH 4432/4433 transducer travels down through the water, spreading outwards to form a rough cone shape. However, the cone width is dependent upon the frequency of the pulse; at 83 kHz it is 20°, whereas at 200 kHz it is 14°. The chart shows how the cone width varies over depth for each frequency used. Figures are approximate.

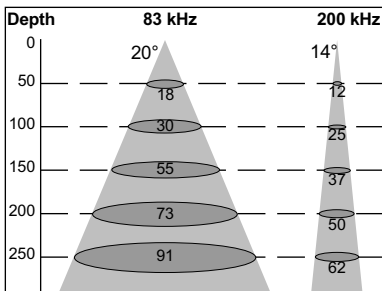

Water Depth	Cone width at 83 kHz	Cone width at 200 kHz
10	4	2
20	7	5
30	11	7
40	15	10
50	18	12
60	22	15
70	25	17
80	29	20
90	33	22
100	36	25
150	55	37
200	73	50
300	109	75
400	146	100
500	182	125
600	218	149
700	255	174
800	291	199
900	328	224
1000	364	249

The differences in the cone width affect what is displayed. See section 4-2 Single and Dual Frequency fishfinding.

Shadows

Shadows are created around areas where the ultrasonic beam cannot 'see'. These areas include hollows on the bottom or beside rocks and ledges, where the strong echoes returned off the rocks obscure the weak echoes of the fish and may also create a double bottom trace. See following for an example of the sonar display in such an environment. A double bottom trace is shown on the display.

When looking for fish with the wide angled 83 kHz frequency, be aware of increased shadows. Use the high frequency 200 kHz in areas that have rocks and ledges because this frequency reduces the shadow effect considerably.

Example of shadows

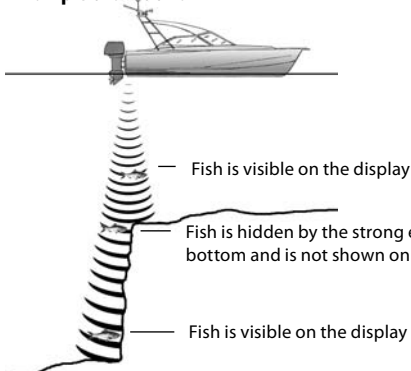

Sonar display of same area

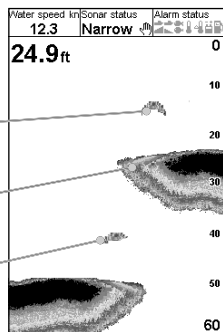

4-2 Single and Dual frequency fishfinding

When to use 200 kHz

The 200 kHz frequency is best for seeing deep bottoms, showing detail and reducing noise.

When to use 83 kHz

The 83 kHz frequency has a wider beam—good for locating features that can be examined in detail at 200kHz.

Auto frequency

This shows 200kHz detail on screen, but uses 83kHz beam for locating fish further from boat.

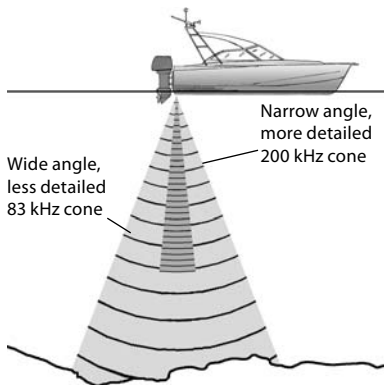

Comparison of the same fish scenario displayed at different frequencies:

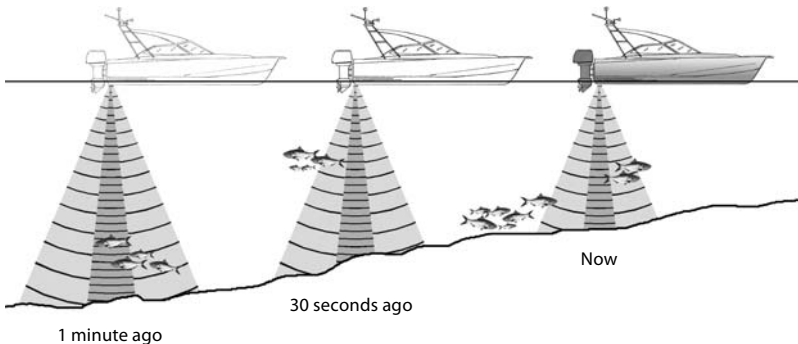

83 kHz display

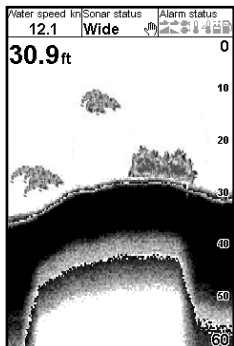

Note the wider bottom trace

200 kHz display

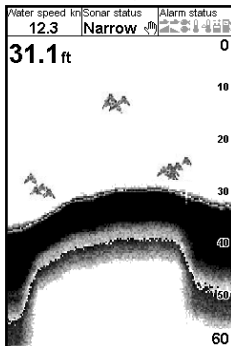

Note the smaller, defined fish arches and more bottom detail.

200/83 KHz display

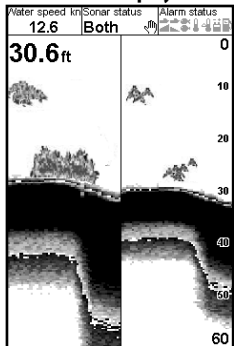

Dual screen

4-3 Fish detection and display

Where to find fish

Underwater features like reefs, wrecks and rocky outcrops attract fish. Use the 83/200 kHz frequency display to find these features, then look for fish by passing over the feature slowly several times using the Zoom display (see section 5-2 Sonar Zoom display). If there is a current, the fish will often be found downstream of the feature.

When fishing with the FISH 4432/4433 with the Fish symbols Off, a weak fuzzy band may appear between the bottom trace and surface. This might indicate a thermocline - a rapid change in water temperature, such as the edge of a warm or cold current. The temperature difference can form a barrier which the fish may not swim through. In fresh water, fish often collect around a thermocline.

Fish symbols

The fish symbol can be customized or switched off altogether so that the echoes are not converted to fish symbols on the display. See section 3-2 Setup > Sonar. The differences between Fish symbol On and Off are:

Fish symbols On

Using Navman's SBN-II sonar technology the fishfinder analyses all echoes and eliminates most false signals and clutter so that remaining targets are most likely fish. Depending on the strength of the remaining echoes, they are displayed as either small, medium or large fish symbols - with or without depth. While the SBN-II processing is very sophisticated it is not foolproof - there will

be times when the fishfinder will not be able to differentiate between large air bubbles, rubbish containing air, fishing floats etc. and genuine fish.

The picture shows the Sonar display with the Fish symbol: symbol + depth:

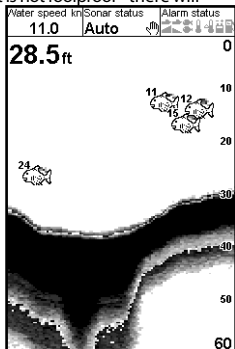

Fish symbols Off

For experienced users this always provides the best information as every echo is displayed, whether it is surface clutter, a thermocline or a fish.

The picture in section 4-1 Interpreting the display, shows the Sonar display with the Fish symbols Off. The fish appear as arches.

Fish arches

In good conditions and with Fish symbols Off, a fish passing through the cone-shaped ultrasonic pulse is displayed as a fish arch. The 83 kHz frequency uses a wider cone than the 200 kHz frequency. This makes the fish arches easier to see.

A fish arch occurs when a fish enters the weak edge of the sonar cone, generating a weak echo that is displayed as the first pixel of the fish arch. As the fish moves closer to the middle of the cone, the distance between the transducer and the fish reduces and the echo is displayed at progressively shallower depths, producing the start of an arch. When the fish passes directly beneath the middle of the cone, the echo becomes strongest and thickest. As the fish passes out of the middle of the cone the reverse happens with a progressively weaker and deeper echo.

There are many reasons why fish arches may not be seen. For example:

- Poor transducer installation (see *Transom Transducers Installation Guide*).
- If the boat is anchored then fish will tend to show on the display as horizontal lines as they swim into and out of the transducer sonar beam. Slow speeds in deeper water give the best fish arch returns.
- Range is important. It will be much easier to see fish arches when using zoom mode to concentrate on a particular section of water, rather than just displaying everything from the surface to the bottom. Zooming increases screen resolution and is necessary for good fish arches.

- It is difficult to get fish arches in shallow water as the transducer sonar beam is very narrow near the surface and fish do not stay within the beam long enough to display an arch. Several fish in shallow water tend to display as randomly stacked blocks of pixels.
- Wave motion may result in distorted fish arches

4-4 Gain

Gain (sensitivity) controls the amount of detail displayed on the FISH 4432/4433. Understanding how to set suitable Gain settings is important for optimum performance.

The Navman fishfinder has three gain modes, Cruising, Fishing and Manual.

- **Cruising Mode**
Use this mode to show only the bottom and large fish.
- **Fishing Mode**
Use this mode to show as much detail as possible.
- **Manual Mode**
The gain can be adjusted by the user to compensate for water depth and clarity.

High Gain settings may amplify the normal background noise until it appears as random pixels.

Changing between Cruising, Fishing and Manual

To change between Cruising, Fishing and Manual

1. From any Sonar display, press **ENT**.
2. Use the \wedge or \vee cursor keys to highlight mode option, then use the $>$ cursor key then select desired option from list.

Adjusting Gain and Threshold settings

The gain settings and the threshold settings can be adjusted independently for each frequency (83kHz and 200 kHz).

Use threshold to eliminate colors in the sonar display.

1. From any Sonar display, press **ENT**.
2. Use the \wedge or \vee cursor keys to highlight the desired setting, then use the $>$ cursor key to change it.

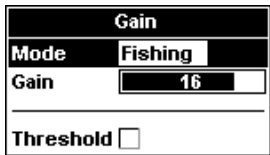

Note: The Gain mode automatically changes to Manual Gain if the gain or threshold settings are adjusted by the user.

Obtaining the best results

To obtain the best detection capability for both fish and bottom we recommend the use of the Sonar A-Scope display:

1. Set the threshold to 0%.
2. Adjust the gain until the threshold line is just to the right of the unwanted noise.

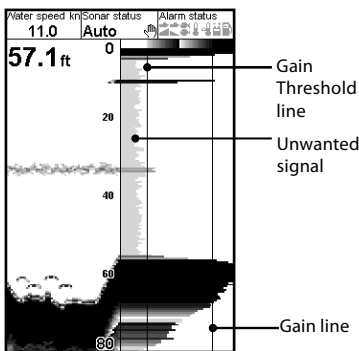

4-5 Range

Range is the vertical depth displayed on the FISH 4432/4433.

The Navman fishfinder has two range modes, Auto Range and Manual Range:

- In Auto Range, the fishfinder adjusts the depth range automatically so the bottom is always shown in the lower part of the display. The use of Auto Range is recommended for normal conditions.
- In Manual Range, the fishfinder shows only a selected depth range. In areas of rapidly changing bottom depth, such as the sea floor around pinnacles, it can be useful to prevent the display from rescaling to always show the bottom. If the bottom is deeper than the specified depth range, it will not be shown on the display.

Changing the Range Mode

Press the + or - key to change to Manual Range mode and to increase or decrease the range to the desired depth. Values can be set between 10 ft. (3 m) to 1000 ft. (300 m).

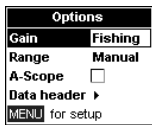

To change from the current mode:

1. From any Sonar display, press **MENU** to display the Options menu.
2. Highlight **Range**, then use the cursor keys to select **Auto** or **Manual**.
3. Press **ENT** to confirm.

Tip: To quickly enlarge from manual to auto-range hold down + or - key for 1.5 seconds.

Zoom Range and Zoom Offset

On the Sonar Zoom and Sonar Bottom displays, a vertical bar is shown on the far right of the display. This is the zoom bar. The zoom bar shows the zoom range; that is, the area that is magnified.

Use the < or > cursor keys to adjust the zoom range.

Use the ^ or v cursor keys to adjust the zoom offset.

5 The Displays

Press **DISP** to show the Display menu. Use < or > to select display tab, then select a particular display using the ^ or v cursor keys.

The Display menu is summarized here and each display is shown in the following sections.

Most displays have an Options menu so that relevant features can be changed quickly.

The Display menu

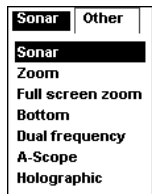

Note: Refer to Section 3-2 Setup > Sonar, for information about customizing features on the sonar displays.

- Sonar display at a single or mixed frequency (section 5-1)
- Sonar split display with zoomed section (section 5-2)
- Show zoomed section of sonar
- Sonar flat bottom trace in zoomed section (section 5-3)
- Sonar split display with 83 and 200 frequencies (section 5-4)
- Sonar split display with echo strength (section 5-5)
- Show perspective view of sonar (section 5-6)

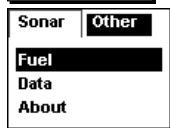

- Fuel data (section 5-7)
- Water temperature and depth history and boat data (section 5-8)
- Product and wiring information (section 5-9)

5-1 Sonar display

Data header, set up to show the boat speed, sonar status etc.

Depth (medium size digits)

To show the Sonar display, press **DISP** and select **Sonar** Tab, select **Sonar** and press **ENT**.

This display scrolls from right (most recent echoes) to left (oldest echoes) at the selected frequency (see section 3-2 Setup > Sonar).

To change items, press **MENU** until the **Options** menu is shown.

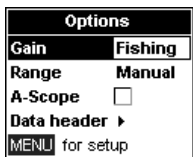

Gain is explained in section 4-4 Gain.

Range is explained in section 4-5 Range.

A-scope is explained in section 5-5 Sonar A-Scope display.

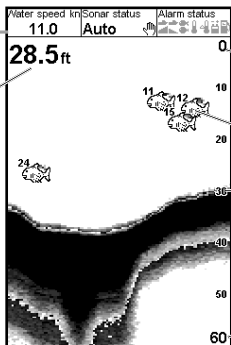

Surface

Fish symbols with depth

Bottom

Range

Data header

The data header can be selected on or off.

When selected, it is a customizable feature that can be used to display up to 9 data items, such as alarms or water temperature.

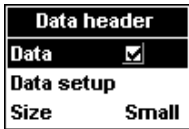

To customize the size of the Data header, highlight **Size** and press **ENT**. There is a choice of **Small** and **Large**.

To customize the data items to be displayed:

1. Highlight **Data setup** and press **ENT**. The Data header increases in size to display all data fields. Some data fields may be blank.
2. Use the cursor keys to move from data field to data field.
3. Press **ENT** at any data field to show the list of data items that can be displayed there.

5-2 Sonar Zoom display

To show the Sonar Zoom display, press **DISP** and select **Sonar Tab**, select **Sonar Zoom** and press **ENT**.

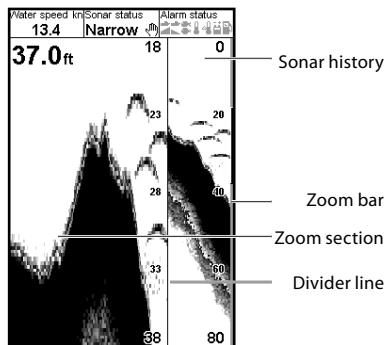

The split display shows the sonar history on the right side and the zoom section on the left.

The zoom bar on the far right shows the area that is magnified in the zoom section. See section 4-5 Range, for information about adjusting the Zoom Range and Zoom Offset.

To change items, press **MENU** until the **Options** menu is shown.

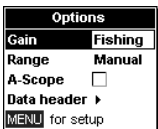

4. Highlight the required data item and press **ENT**. The data item is immediately displayed in that data field.
5. Press **ESC** when finished and the Data header resizes automatically.

Sonar History

To review an old sonar echo, use **<** and **>** to move back and forward through the sonar history. The time since the echoes shown on the screen were recorded is displayed at the bottom of the screen. Press **ESC** to return to the most recent echo.

Gain

Gain is explained in section 4-4 Gain.

Range

Range is explained in section 4-5 Range.

A-Scope

A-Scope is explained in section 5-5 Sonar A-Scope display.

Bottom lock

If **Bottom lock** is **selected**, the zoom section moves so the bottom is always displayed in the zoom section, regardless of changes in depth.

If **Bottom lock** is **not selected**, the bottom will not be displayed in the zoom section when it is outside the range covered by the zoom bar.

Using the Bottom Lock and the A-Scope features together can be a powerful aid in recognising the type of bottom.

Split Ratio

Use this to change the split ratio between the zoom and the sonar history sections displayed. The default split ratio is 50%.

1. Highlight **Split Ratio** and press **ENT**. A left arrow and right arrow appear on either side of the divider line.
2. Use the **<** or **>** cursor keys to adjust the position of the divider line, then press **ENT**. The adjustable range of the split ratio is from 20% to 80%. For 100% zoom, use 'full-screen zoom' display.

Data header

Data header is explained in section 5-1 Sonar display.

5-3 Sonar Bottom display

To show the Sonar Bottom display, press **DISP** and select **Sonar Tab**, select **Sonar Bottom** and press **ENT**.

This shows a split display, with the sonar history on the right side and the zoom section on the left. The bottom signal is shown as a flat trace in the centre of the zoom section.

Showing the bottom as a flat trace can make it easy to compare the echo strengths shown in the bottom signals. This can help to identify the type of bottom and objects close to the bottom.

The zoom bar can only indicate the zoom range. It cannot indicate the zoom offset as this changes for each sounding displayed on the display.

5-4 Sonar 83/200 display

To show the Sonar 83/200 display, press **DISP** and select **Sonar Tab**, select **Sonar 83/200** and press **ENT**.

This shows a split display, with the 83 kHz sonar history on the left side and the 200 kHz sonar history on the right side. Gain settings can be set independently for each frequency. Range settings apply to both sections of the display.

5-5 Sonar A-Scope display

To show the Sonar A-Scope display, press **DISP** and select **Sonar Tab**, select **Sonar A-Scope** and press **ENT**.

Use this to analyse the sonar data in detail and optimize the Gain settings.

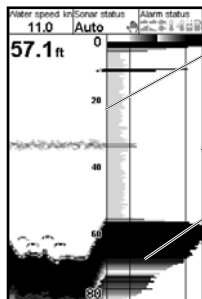

Divider line between sonar history and A-scope

Gain setting (strongest echo for display)

Gain threshold (weakest echo for display)

The zoom bar is fixed in the middle of the display.

See section 4-5 Range, for information about adjusting the Zoom Range and Zoom Offset.

To change items, press **MENU** until the Options menu is shown.

Gain is explained in section 4-4 Gain.

Range is explained in section 4-5 Range.

A-scope is explained in section 5-5 Sonar A-Scope display.

Data header is explained in section 5-1 Sonar display.

Bottom lock and Split ratio are explained in section 5-2 Sonar Zoom display.

To change items, press **MENU** until the Options menu is shown. Gain is explained in section 4-4 Gain.

Range is explained in section 4-5 Range.

A-scope is explained in section 5-5 Sonar A-Scope display.

Data header is explained in section 5-1 Sonar display.

Split ratio is explained in section 5-2 Sonar Zoom display.

The user can define the level of the weakest and strongest echoes to be shown on the sonar displays, by using the Gain and Threshold settings. See section 4-4 Gain, for more information.

The strength of an echo at a particular depth is shown by the length of the horizontal line at that depth. A strong echo produces a long line whereas a weak echo produces a short line.

To change items, press **MENU** until the Options menu is shown.

Gain is explained in section 4-4 Gain.

Range is explained in section 4-5 Range.

Data header is explained in section 5-1 Sonar display.

Split ratio is explained in section 5-2 Sonar Zoom display.

Fish recognition

The echo strengths shown on the A-scope can be useful in recognising the type of fish. Different species of fish have different sizes and shapes of swim bladders. The air in the swim bladder reflects the ultrasonic pulse, so the strength of the echo varies between fish species according to the size and shape of the swim bladder.

When fishing among a school of fish and catching them, note the fish species and the strength of the echo that it returns on the A-scope. Then, when that particular echo is seen at future times on the fishfinder, it is likely to be the same fish species.

5-6 A-Scope perspective view

The strength of echoes on this view are determined by the 'height' of the echo shown on the screen.

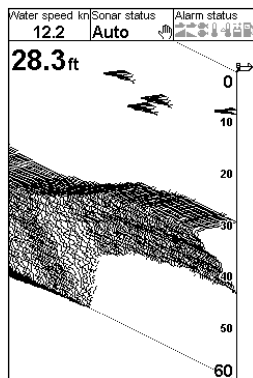

5-7 Fuel display (4433 only)

To show the Fuel display, press **DISP** and select **Other Tab**, select **Fuel** and press **ENT**.

There are no options.

(See section 3-3 Setup > Fuel for information about setting up the fuel values. If the number of engines is set to 0, the fuel features are turned off.)

Used shows total fuel used since this was last reset with the **Clear Used** command.

Remaining shows the amount of fuel remaining in the tank(s).

Flow shows the fuel consumption per hour. For twin engine installations, the fuel flow for each engine is shown separately. This is useful for checking that both engines are under the same load.

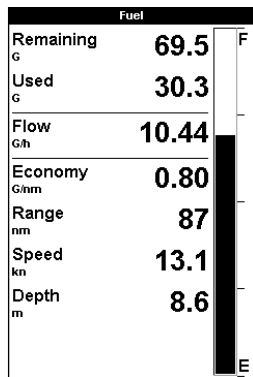

Economy is the distance travelled per unit of fuel used. The Fishfinder calculates this using the fuel used and boat speed (water speed or GPS speed - which ever is selected as the speed source - see section 3-3 Setup > Fuel).

The bigger this number, the better the fuel economy. Adjust the throttle and trim to achieve the best fuel economy.

Note: when water speed is selected as the speed source, calibration of the boat speed measurement is essential for an accurate fuel economy reading - see section 3-8 Setup > Calibrate.

5-8 Data display

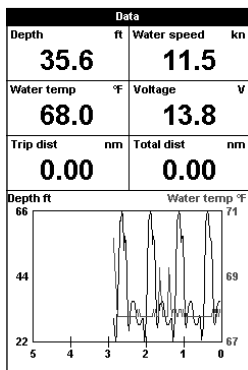

To show the Data display, press **DISP** and select **Other Tab**, select **Data** and press **ENT**.

This shows a graph of the water temperature and depth over the last 20 minutes and selected data items.

The graph is useful for locating warm and cold spots in the water.

To change data items:

1. Press **MENU** until the **Options** menu is shown.
2. Highlight **Data setup** and press **ENT**.
3. Use the cursor keys to move from data field to data field.
4. Press **ENT** at any data field to show the list of data items that can be displayed there.
5. Highlight the required data item and press **ENT**. The data item is immediately displayed.
6. Press **ESC** when finished.

Time base of graph can be changed by pressing **Menu**, selecting **Time Base** with cursor key, pressing **ENT**, and selecting the required time base from list - 5min, 10min, 20min, 1hr, 2hr.

5-9 About display

About	
FISH 4433	
Software 0.7.1 04/04/2005	
Copyright © 2005 Navman NZ Limited	
Hardware	1.0
Gateware	0
Serial number	Unknown
Power/comms cable	
1 Black	Ground
3 White	NMEA out
5 Red	+12V in
7 Yellow	Auto power
8 Green	Ext Alarm
Sonar cable	
Transducer	

To show the About display, press **DISP**, select **Other Tab**, select **About** and press **ENT**. There are no options.

This shows the fishfinder model number, the software and hardware versions and wiring information.

Note the software version before contacting your Navman dealer for technical advice.

For more information on wiring, see section 6-5 Wiring options.

For more information on NMEA and NavBus, see section 6-6 Systems of several instruments.

6 Installation and Maintenance

Correct installation is critical to the performance of the FISH 4432/4433. There are two components to install, the display unit and

the transducer. It is vital to read the entire installation section of this manual before attempting to install the components.

Wiring Options

The power/data cable contains 5 wires:

Wire	Function
Black	Ground (power negative)
White*	NMEA out
Red	Positive power in, 12 V DC
Yellow	Auto power in (connect to red wire. Positive power in, to enable Auto power).
Green*	External beeper or light out, switched to ground, 30 V DC 200 mA maximum.

Note: The cable shield is connected to Pin 1 (black wire) and does not need to be grounded.

* Denotes FISH 4433 only.

Warning

1 Amp fuses must be positioned where shown in the wiring diagrams.

Basic wiring

This requires the FISH 4432 and FISH 4433 to be powered on manually with the **ⓘ** key.

Black wire: Connect this to the negative battery terminal.

Red wire: Connect this to the positive battery terminal after the main switch. Fit a 1 Amp fuse as shown.

Yellow wire: Connect this to the black wire. This disables the engine hours counter.

Six wiring options are described in this section:

- **Basic wiring.** This does not start the fishfinder automatically when the boat ignition is switched on and it disables the engine hours counter.
- **Auto power wiring.** This must be used for the engine hours and fuel computer options.
- **Secondary Alarm wiring**
- **NMEA wiring**
- **Single engine fuel wiring**
- **Twin engine fuel wiring**

Note: If a wire colour is not specifically mentioned, it is not used in that wiring option.

Section 6-5 Systems of several instruments, describes NMEA and NavBus.

Power on the fishfinder manually whenever the main switch is on.

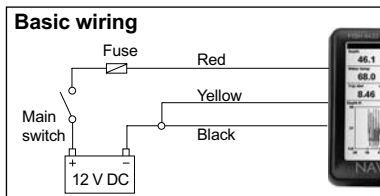

NMEA wiring Option (FISH 4433 only)

White Wire: Use this, if desired, to connect the fishfinder to other NMEA instruments such as Navman's REPEAT 3100. (See section 6-5 Systems of several instruments.)

Secondary alarm wiring option (FISH 4433 only)

Green Wire: Use this to connect a secondary alarm indicator such as a flashing light or external beeper with a built-in drive circuit. See the Auto power wiring diagram.

If the external beeper or light requires more than 200 mA total, fit a relay. Consult your Navman dealer for more advice.

Fuel kit wiring (FISH 4433 only)

See the *Fuel Kit Installation Guide* for information about the fuel transducer cable.

Wire the power cable for Auto power (as described in this section) to make sure the fuel counter starts as soon as the engine starts.

For twin engine installation, a T-connector needs to be installed on the fuel transducer cable.

Auto power option

Black wire: Connect this to the negative battery terminal.

Red wire: Connect this to the positive battery terminal after the main switch. Fit a 1 Amp fuse as shown.

Yellow wire: To enable the engine hours counter and fuel counter; and to start the fishfinder automatically when the ignition is turned on, connect the yellow wire to the ignition system through a 1 Amp fuse.

Note: *The fishfinder cannot be turned off while the ignition is on.*

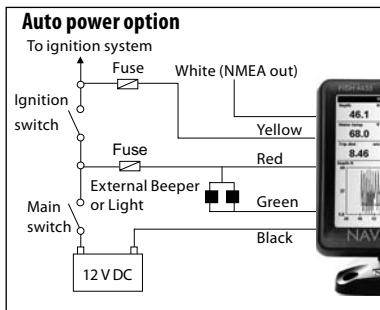

Through hull transducers

Through hull transducers are supplied with 'Y' adapter cable for connection of both transducers into top socket with blue nut.

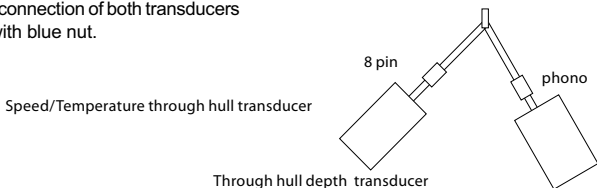

6-1 What comes with this product?

Standard configuration:

- FISH 4432/4433 display unit
- Power cable
- Mounting bracket (screws included)
- Warranty registration card
- This manual
- Sun cover for display unit
- Flush mounting kit
- Dual frequency transom transducer (includes cable kit and screws)
- Transom Mount Transducer Installation Manual.

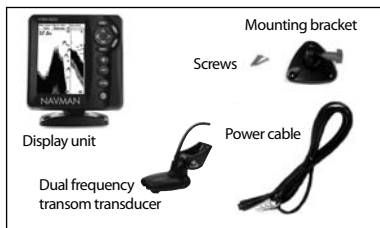

6-2 Options and Accessories

- TRACKER series of chartplotters
- Through hull dual frequency transducer
- Through hull speed/temperature transducer
- Fuel flow kit (single or twin engine)
- Replacement paddle wheel
- SmartCraft Gateway*
- REPEAT 3100 (see section 6-6 Systems of several instruments)*
- Diesel 3200 for fuel flow on diesel engines*

Please consult your Navman dealer for more information.

* Fish 4433 only

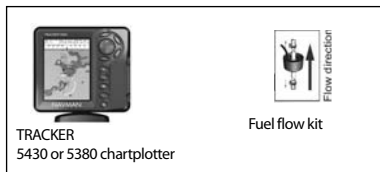

6-3 Mounting and removing the display unit

There are two mounting arrangements:

- **Flush mounting** requires a solid panel with access behind for wiring and mounting screws. After flush mounting, the FISH 4432/4433 cannot be tilted or moved after installation to reduce any unwanted glare or reflections. Carefully select the best viewing position before installation. This would generally be in a shaded area.
- **Bracket mounting** requires a panel for mounting the bracket. Ensure that the panel is not likely to deform and is not subject to excessive vibration. The bracket can be tilted and rotated and the FISH 4432/4433 can be removed after each use.

Select a position where the display unit will be:

- At least 4" (100 mm) away from the compass.
- At least 12" (300 mm) away from any radio transmitter.
- At least 4 ft. (1.2 m) away from any antenna.
- Easy to read by the helmsman and crew while underway.
- Protected from physical damage during rough sea passages.
- Easy to access the 12VDC power source.
- Convenient to route the transducer cables.

Flush Mounting

1. Cut a hole in the bulkhead for the display unit using the flush mount template.
2. Drill four holes for the mounting studs using the flush mount template.
3. Screw the four studs into the brass inserts in the back of the display unit.
4. Sit the display unit in place and fit the washers and nuts to the studs.

Bracket Mounting

1. Fix the mounting bracket onto the boat using the three stainless steel screws. Do not overtighten the screws, as the bracket may not rotate.
2. Push the display unit onto the mounting bracket and tighten it firmly using the knob on the mounting bracket.
3. Attach the cables.

6-4 Systems of several instruments (4433 Only)

Several Navman instruments can be connected together to share data.

The FISH 4432/4433 is particularly suited to work with the TRACKER 5430 (4.3" greyscale)/5380 (3.8" color) - Navman's GPS chartplotters with worldwide coverage.

There are two ways of connecting instruments together; NavBus or NMEA.

NavBus

NavBus is a Navman proprietary system that allows systems of multiple instruments to be built using a single set of transducers. When instruments are connected by NavBus:

- If the units, alarms or calibration are changed in one instrument, then the values will automatically change in all instruments of the same type.
- Each instrument can be assigned to a group of instruments. Then, if the backlight setting is changed in one group,

Removing the display unit

The display unit can be removed after each use for protection against the environment or security reasons.

When removing the display unit, ensure that the plugs left in the boat are not exposed to the elements. Push the attached dust covers over the exposed ends of the plugs. Keep the display unit in a dry clean place such as an optional Navman carry bag.

it will automatically change for the other instruments in that group. However, the backlight setting will not change for instruments in different groups.

- If an alarm sounds, mute it by clearing the alarm on any instrument which can display that alarm.

NMEA

NMEA is an industry standard for marine instrument connections. Data sent by one instrument over an NMEA line can be read and displayed by another instrument that accepts NMEA 0183 Version 2. It is not as flexible as NavBus as it requires dedicated connections between instruments.

Please contact your Navman dealer for information on Navman's full range of NMEA enabled instruments and connection options.



REPEAT 3100

Repeater for depth, speed, water temperature and battery voltage. Accepts NavBus or NMEA data inputs from other instruments.



DEPTH 2100
Depth Repeater



TRACKER 5430/5380
Color GPS Chartplotter with
worldwide coverage

6-5 Cleaning and maintenance

To avoid damage, clean the screen **only** with a damp cloth and mild detergent when dirty or covered in sea salt. Avoid abrasive cleaners, petrol or other solvents.

Cover or remove a transom-mounted transducer when repainting the hull. If painting over a through hull transducer with antifouling paint, use only one coat of paint. Remove the previous coat of antifouling paint by sanding it lightly.

To optimize performance, avoid walking on or jamming cables and connectors. Keep the transducer free of weed, paint and debris. Do not use a high pressure water blast on a speed sensor paddlewheel as it may damage the bearings.

When not in use, the FISH 4432/4433 can be removed from the installation bracket and stored in the Navman carry bag, or left on the installation bracket and securely covered with the sun cover supplied.

Appendix A - Specifications

Specifications	FISH 4432	FISH 4433
Display type:	16 Greyscales Screen Resolution 360 high x 240 wide(pixels) White LED backlighting	
Display size:	4.3" (110mm) diagonal	
Supply voltage:	10 to 16V DC	
Supply current at 13.8 V:	170 mA min - no backlighting 250 mA max - full backlighting	
Operating temperature:	32° to 122°F (0° to 50°C)	
Environment:	IPx6 and IPx7	
Standards Compliance EMC:	USA FCC Part 15 Class B Europe (CE) EN60945 (EMC only) New Zealand and Australia (C-Tick) CISPR 22	
Depth:	2 ft (0.6 m) to 750ft with supplied transducer. Depth capabilities of transducer used and installation and water clarity.	
Output power:	Variable, up to 250W RMS	
Dual Transducer frequency:	200 kHz / 83 kHz	
Receiver sensitivity:	Better than 10 micro volts RMS Dynamic range 4.0 million to 1 (120 dB)	
Typical depth acquisition time from startup:	2 seconds at 100 ft (30 m)	
Transom transducer cable length:	33 ft (10 m)	26 ft (8 m)
Temperature measurement range:	32° to 99.9°F (0° to 37.7°C) Resolution of 0.1° unit	
Speed range:		1 to 50 kn (57.5 mph, 96.6 kph)
Communications:		NMEA 0183 (Ver 2.0) 4800 baud NavBus
NMEA Output: NMEA (0183) is a standard for interfacing marine electronic devices. The Navman fishfinder can output the following sentences		DBT (Depth Below Transducer) DPT (Depth and Keel offset) VHW (Speed) VLW (Distance traveled – Total & Trip) MTW (Sea Water temperature) XDR (Battery voltage and fuel flow)
Fuel Computer:* (optional fuel transducer(s) required) *4433 only	Outboard carbureted two stroke and EFI petrol/gasoline engines: 30 to 300 hp Outboard four stroke petrol/gasoline engines: 90 to 300 hp Inboard petrol/gasoline engines: 50 to 300 hp Minimum flow rate: 1.3 U.S. gallons per hour (5 litres per hour) Maximum flow rate: 34 U.S. gallons per hour (130 litres per hour)	
SmartCraft Support:	No	Yes, single engine

Appendix B - Dimensions

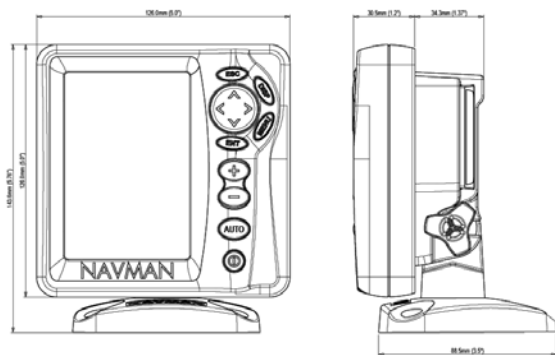

Appendix C - Troubleshooting

This troubleshooting guide is written with the assumption that the user has read and understood the relevant sections in this manual.

It is possible in many cases to solve difficulties without having to send the display unit back to the manufacturer for repair. Please follow this troubleshooting section before contacting the nearest Navman dealer.

There are no user serviceable parts. Specialized methods and testing equipment are required to ensure that the display unit is reassembled correctly and is waterproof. Users who service the product themselves will void the warranty.

Repairs to the product may only be carried out by a service centre approved by Navman. If the product must be sent into a service centre for repair, it is essential to send in the transducer(s) at the same time.

More information can be found on our Website: www.navman.com.

1. The fishfinder won't turn on:

- The FISH 4432/4433 is designed to operate on a 12 volt battery system, where the voltage may vary from 10 to 16 volts. If an excessive voltage is supplied, the unit will turn off/not start.
- Check that the power cable connector at the back of the display unit is securely plugged in and the collar is locked in place.

The collar must be secure for watertight connection.

- Measure the battery voltage while the battery is under load - turn on some lights, radio or other electrical equipment connected to the battery. If the voltage is less than 10 volts:
 - the battery terminals or wiring on the terminals may be corroded.
 - the battery may not be charging correctly or may need replacing.
- Inspect the power cable from end to end for damage such as cuts, breaks, squashed or trapped sections.
- Ensure that the red wire is connected to the positive battery terminal and the black wire to the negative battery terminal. If wired for the Auto Power option, ensure the yellow wire is connected to the ignition circuit. Also check the boat's main switch circuit (see section 6-5 Wiring options).
- Check for corrosion on the power cable connector and clean or replace if required.
- Check fuses that are placed in line with the power cable. A fuse can be blown despite appearing to be good or the fuse may be corroded. Test the fuse or replace it with a fuse known to be good.

2. The fishfinder won't turn off:

The fishfinder may have been wired for Auto power. In this case, the fishfinder cannot be turned off while the ignition power is on. (See Auto power wiring in section 6-5 Wiring options.)

3. The fishfinder operates erratically:

- a) Check that the transducer does not have debris (e.g. weed, plastic bag) caught around it.
- b) The transducer may have been damaged during launching, running aground or while underway with debris etc. If the transducer has been impacted, it may have been kicked up on the bracket. If it is not physically damaged, reset the transducer back to its original position. (See the *Transom Transducer Installation Guide*.)
- c) When the transducer is less than 2 ft. (0.6 m) from the bottom, the depth readings may become inconsistent and erratic.
- d) Manual Gain may be set too low, which may cause weak bottom echo or no fish signals. If in Manual Gain, try increasing the Gain.
- e) Ensure the back of the bottom surface of the transducer is slightly lower than the front and the front is as deep in the water as possible in order to minimize the generation of bubbles through cavitation. (See the *Transom Transducers Installation Guide*.)
- f) Check the transducer and power cable connectors at the back of the display unit are securely plugged in and the collars are locked in place. The collars must be secure for watertight connection.
- g) Inspect the power cable from end to end for damage such as cuts, breaks, squashed or trapped sections.
- h) Ensure there is not another fishfinder or depth sounder turned on, which may interfere with this fishfinder.
- i) Electrical noise from the boat's engine or an accessory may be interfering with the transducer(s) and/or the Navman fishfinder. This may cause the fishfinder to automatically decrease the Gain unless using Manual Gain.

The fishfinder thus eliminates weaker signals such as fish or even the bottom

from the display. This may be checked by switching off other instruments, accessories (e.g. bilge pump) and the motor until the offending device is located. To stop problems from electrical noise, try:

- re-routing the power and transducer cable(s) away from the boat's other electrical wiring.
- routing the display unit's power cable directly to the battery with an in-line fuse.

4. Bottom is not displayed:

- a) The fishfinder may have Manual Range selected and the depth may be outside the range value selected. Either change the fishfinder to Auto Range or select another depth range (see section 4-5 Range).
- b) The depth may be outside the fishfinder's range. While in Auto Range, the display unit will display "--" to indicate that there is no bottom detected. A display of the bottom should reappear when in shallower water.

5. The bottom is displayed too far up the screen:

The fishfinder may have Manual Range selected and the selected Range value is too high for the depth. Either change the fishfinder to Auto Range or select another depth range (see section 4-5 Range).

6. Bottom echo disappears or erratic digital reading while the boat is moving:

- a) Ensure the back of the bottom surface of the transducer is slightly lower than the front and the front is as deep in the water as possible in order to minimize the generation of bubbles through cavitation. (See the *Transom Transducers Installation Guide*, for more information.)
- b) The transducer may be in turbulent water. Air bubbles in the water disrupt the echoes returned, interfering with the fishfinder's ability to find the bottom or other targets. This often happens when the boat is reversed. The transducer must be mounted in a smooth flow of water in order for the fishfinder to work at all boat speeds.
- c) Electrical noise from the boat's motor can interfere with the fishfinder. Try some suppression spark plugs.

7. If the fishfinder beeps when turned on but nothing is displayed:

The fishfinder may be operating, but the backlight settings may have been set too low. See section 2 Basic Operation, to adjust the fishfinder backlight. Press **Ⓚ** twice to restore default backlight settings.

8. The wrong language is displayed:

See section 3-1 Setup > System.

9. Fuel used or remaining seem inaccurate:

- a) If the engine is run while the fishfinder is powered off, the fishfinder does not record the amount of fuel used during that engine run. Consequently, the **Fuel remaining** value will be higher than the actual amount of fuel remaining in the tank.

To avoid this problem, use the Auto Power Wiring option described in section 6-5 Wiring options. This ensures that the fishfinder powers on automatically whenever the boat's ignition is switched on.

- b) In rough seas, fuel may surge back and forth through the fuel transducer, resulting in incorrect readings. Try installing a one-way valve between the fuel transducer and the fuel tank.
- c) The **Set remaining** fuel value must be reset after every refuelling (see section 3-3 Setup > Fuel).
- d) The fuel tank may not refill to the same capacity each time due to air pockets. This is particularly noticeable with underfloor tanks.
- e) Fuel transducers wear out over time and should be replaced after every 5000 litres of fuel.

10. Flow indicates no fuel or low fuel:

- a) Check that the number of engines is set to 1. See section 3-3 Setup > Fuel.
- b) Check that the fuel cable connectors are securely plugged in and the collar is locked in place. The collar must be locked in place to give a watertight connection.
- c) A fuel transducer may be clogged. If so, remove the transducer from the fuel line and gently blow through it in the opposite direction to the fuel flow.

A fuel filter between the fuel transducer

and the fuel tank must be installed as per the fuel installation guide. Failure to do so will void the warranty.

- d) Inspect the fuel cable from end to end for damage such as cuts, breaks, trapped or squashed sections.
- e) Check that the fuel filter is clean.

11. A twin engine installation shows only one flow rate:

- a) Check that the number of engines is set to 2. See section 3-3 Setup > Fuel.

12. Erratic Fuel Flow readings:

- a) The fuel flow transducer may have been mounted too close to the fuel pump or may be subject to excessive vibration. Refer to the installation instructions supplied with the fuel transducer.
- b) Check for leaks in the fuel line or in the fuel pickup in the tank.
- c) The **Flow filter** value is not suitable for the engine. Check that the value is not set to zero, then try increasing the value until a steady flow rate is shown. See section 3-3 Setup > Fuel.
- d) A higher fuel **Flow filter** setting be used on EFI (fuel injected) engines. See section 3-3 Setup > Fuel.

13. There is no reading for fuel economy:

- a) The boat must be travelling through the water to generate an **Economy** reading.
- b) Check that the paddlewheel on the transducer is spinning freely and that the two magnets in the paddlewheel are still in place.

14. There is a double bottom trace displayed:

- a) The boat may be in an area that generates shadows. See section 4-1 Interpreting the display.
- b) In shallow water, the echoes may bounce. Reduce the gain setting (see section 4-4 Gain) and/or reduce the sonar pulse power (see section 3-2 Setup > Sonar).
- c) Decrease the Range.

15. No Sonar Display

Sonar is turned off. See Section 3-1 System > Setup.

NORTH AMERICA
 BNT - Marine Electronics
 30 Sudbury Rd, Acton, MA 01720.
 Toll Free: +1 866 628 6261
 Fax: +1 978 897 8264
 e-mail: sales@navmanusa.com
 web: www.navman.com

OCEANIA
 Australia
 Navman Australia Pty. Limited
 Suite 2, 408 Victoria Road
 Gladesville, NSW 2111, Australia.
 Ph: +61 2 9879 9000
 Fax: +61 2 9879 9001
 e-mail: sales@navman.com.au
 web: www.navman.com

New Zealand
 Absolute Marine Ltd.
 Unit B, 138 Harris Road,
 East Tamaki, Auckland.
 Ph: +64 9 273 9273
 Fax: +64 9 273 9099
 e-mail: navman@absolutemarine.co.nz

Papua New Guinea
 Lohberger Engineering,
 Lawes Road, Konedobu.
 PO Box 810, Port Moresby.
 Ph: +675 321 2122
 Fax: +675 321 2704
 e-mail: loheng@online.net.pg
 web: www.lohberger.com.pg

LATIN AMERICA
 Argentina
 Costanera Uno S.A.
 Av Pte Ramón S. Castillo y Calle 13
 Zip 1425 Buenos Aires, Argentina.
 Ph: +54 11 4312 4545
 Fax: +54 11 4312 5258
 e-mail: purchase@costanerauno.com.ar
 web: www.costanerauno.ar

Brazil
 Equinautic Com Imp Exp de Equip
 Nauticos Ltda.
 Rua Ernesto Paiva, 139
 Clube dos Jangadeiros
 Porto Alegre - RS - Brasil
 CEP: 91900-200.
 Ph: +55 51 3268 6675
 +55 51 3269 2975
 Fax: +55 51 3268 1034
 e-mail: equinautic@equinautic.com.br
 web: www.equinautic.com.br

REALMARINE
 Av Inf Dom Henrique s/nº - Loja 12
 Marina da Glória - Rio de Janeiro - RJ.
 Brasil
 Cep: 2021-140
 Ph: +55 21 3235-6222
 Fax: +55 21 3235-6228
 e-mail: vendas@realmarine.com.br
 website: www.realmarine.com.br

Chile
 Equimar
 Manuel Rodriguez 27
 Santiago, Chile.
 Ph: +56 2 698 0055
 Fax: +56 2 698 3765
 e-mail: mmontecinos@equimar.cl
 Mera Vennik
 Colon 1148, Talcahuano,
 4262798, Chile.
 Ph: +56 41 541 752
 Fax: +56 41 543 489
 e-mail: meravennik@entel.chile.net

Mexico
 Mercury Marine de Mexico
 Anastacio Bustamante #76
 Interior 6 Colonia Francisco Zarabia,
 Zapapan, Jalisco, C.P.45236 Mexico.
 Ph: +52 33 3283 1030
 Fax: +52 33 3283 1034
 web: www.equinautic.com.br

Uruguay
 Alvaro Burmudez, Nautica
 Puerto del Buco
 11300 Montevideo, Uruguay.
 Ph: Phone & Fax +52 628 6562
 e-mail: alvaro@nautica.com.uy
 web: www.nautica.com.uy

ASIA
 China
 Peaceful Marine Electronics Co. Ltd.
 Guangzhou, Hong Kong, Dalian,
 Qingdao, Shanghai
 1701 Yanjiang Building
 195 Yan Jiang Zhong Rd. 510115
 Guangzhou, China.
 Ph: +86 20 3869 8839
 Fax: +86 20 3869 8780
 e-mail: sales@peaceful-marine.com
 web: www.peaceful-marine.com

India
 Access India Overseas Pvt. Ltd.
 A-98, Sector 21,
 Noida - 201 301, India.
 Ph: +91 120 244 2697
 TeleFax: +91 120 253 7881
 Mobile: +91 98115 04557
 e-mail: vkapil@del3.vsnl.net.in
 Esmario Export Enterprises
 Block No. F-1, 3rd Floor, Surya Towers
 Sardar Patel Rd, Secunderbad 500003.
 Ph: +91 40 2784 5163
 Fax: +91 40 2784 0595
 e-mail: gfjee@hd1.vsnl.net.in
 web: www.esmario.com

Korea
 Kumhomarine Technology Co. Ltd.
 #604-842,2F,1118-15,Janglim1-Dong,
 Saha-Gu, Busan, Korea.
 Ph: +82 51 293 8589
 Fax: +82 51 265 8984
 e-mail: info@kumhomarine.com
 web: www.kumhomarine.com

Japan
 PlusGain Inc.
 1-A 324-3 Matunoki-Tyoo
 Takayama-City, Gifu-Ken, Japan
 Ph: +81 577 36-1263
 Fax: +81 577 36-1296
 email: info@plusgain.co.jp
 web: www.plusgain.co.jp

Maldives
 Maizan Electronics Pte. Ltd.
 Henveyru, 08 Sosunmagu.
 Male', Maldives.
 Mobile: +960 78 24 44
 Ph: +960 32 32 11
 Fax: +960 32 57 07
 e-mail: ahmed@maizan.com.vv

Singapore and Malaysia, Brunei and Indonesia
 RIQ PTE Ltd.
 Blk 3007, 81 Ubi Road 1, #02-440,
 Singapore 408701.
 Ph: +65 6741 3723
 Fax: +65 6741 3746
 e-mail: email@riq.com.sg
 web: www.riq.com.sg

Taiwan
 Seafirst International Corporation
 No. 281, Hou-An Road, Chien-Chen
 Dist. Kaohsiung, Taiwan R.O.C.
 Ph: +886 7 831 2688
 Fax: +886 7 831 5001
 e-mail: seafirst@seed.net.tw
 web: www.seafirst.com.tw

Thailand
 Thong Electronics (Thailand) Co. Ltd.
 923/588 Ta Prong Road, Mahachai,
 Muang Samutakhon/4000, Thailand.
 Ph: +66 34 411 919
 Fax: +66 34 422 919
 e-mail: sales@thongelectronics.com
 admins@thongelectronics.com
 web: www.thongelectronics.com

Vietnam
 HaiDang Co. Ltd.
 763 Le Hong Phong St. Ward 12
 District 10, Hochiminh City, Vietnam
 Ph: +84 8 863 2159
 Fax: +84 8 863 2524
 e-mail: haidang-co@hcm.vnn.vn
 web: www.haidangvnn.com

MIDDLE EAST
 United Arab Emirates
 Kuwait, Oman, Saudi Arabia, Bahrain and Qatar
 Abdullah Moh'd Ibrahim Trading, opp
 Creak Rd. Baniyas Road, Dubai.
 Ph: +971 4 229 1195
 Fax: +971 4 229 1198
 e-mail: sales@amitdubai.com

Egypt
 18 Abou El-Ataheya St., via Abbas
 Al-Akkad St.,
 Nasr City, Cairo Egypt
 Ph: +202 274 2911
 +202 272 8493
 Fax: +202 274 5219
 e-mail: seet@internetegypt.com
Lebanon
 Balco Stores
 Balco Building, Moutran Street,
 Tripoli (via Beirut). - Lebanon
 P.O. Box: 622.
 Ph: +961 6 624 512
 Fax: +961 6 628 211
 e-mail: balco@cyberia.net.lb

AFRICA
 South Africa
 Perteq (Pty) Ltd (Coastal Division)
 16 Paarden Eiland Road.
 Paarden Eiland, 7405
 PO Box 527,
 Paarden Eiland, 7420
 Cape Town, South Africa.
 Ph: +27 21 508 4707
 Fax: +27 21 508 4888
 e-mail: info@kfa.co.za
 web: www.perteq.co.za

EUROPE
 Plastimo International
 15, rue Ingénieur Verrière,
 BP435,
 56325 Lorient Cedex.
 Ph: +33 2 97 87 36 36
 Fax: +33 2 97 87 36 49
 e-mail: plastimo@plastimo.fr
 web: www.plastimo.fr

OTHER COUNTRIES IN EUROPE
 Norway
 ProNav AS
 Friskarvik Maritime Senter,
 Hovlandsveien 52,
 N-4370 Egersund, Norway.
 Ph: +47 51 494 300
 Fax: +47 51 494 300
 e-mail: mail@pronav.no
 web: www.pronav.no
 Finland
 Vator Oy
 Puuskarienne 8,
 00850 Helsinki, Finland.
 Ph: +35 8 040 300 7212
 Fax: +35 8 040 300 7200
 e-mail: info@vator.com
 web: www.vator.com
 Croatia
 Meridian Projekt d.o.o.
 Savska 58,
 Ph: +38 5 1 617 6364
 Fax: +38 5 1 617 6365
 e-mail: navman@meridianprojekt.com
 web: www.meridianprojekt.com

HEADQUARTERS
 Navman NZ Limited
 7-21 Kawana St.
 Northcote.
 P.O. Box 68 155,
 Newton,
 Auckland,
 New Zealand.
 Ph: +64 9 481 0500
 Fax: +64 9 481 0590
 e-mail: marine.sales@navman.com
 web: www.navman.com

Made in New Zealand
MN000457B



FISH 4432 / 4433

Lon 174° 44.535'E

NAVMAN

Lat 36° 48.404'S

